



# **Network Traffic Camera**

## **User Manual**

## **User Manual**

COPYRIGHT ©2018 Hangzhou Hikvision Digital Technology Co., Ltd.

### **ALL RIGHTS RESERVED.**

Any and all information, including, among others, wordings, pictures, graphs are the properties of Hangzhou Hikvision Digital Technology Co., Ltd. or its subsidiaries (hereinafter referred to be “Hikvision”). This user manual (hereinafter referred to be “the Manual”) cannot be reproduced, changed, translated, or distributed, partially or wholly, by any means, without the prior written permission of Hikvision. Unless otherwise stipulated, Hikvision does not make any warranties, guarantees or representations, express or implied, regarding to the Manual.

### **About this Manual**

This Manual is applicable to Network Traffic Camera (hereinafter referred to as “camera”).

The Manual includes instructions for using and managing the product. Pictures, charts, images and all other information hereinafter are for description and explanation only. The information contained in the Manual is subject to change, without notice, due to firmware updates or other reasons. Please find the latest version in the company website (<http://overseas.hikvision.com/en/>).

Please use this user manual under the guidance of professionals.

### **Trademarks Acknowledgement**

**HIKVISION** and other Hikvision’s trademarks and logos are the properties of Hikvision in various jurisdictions. Other trademarks and logos mentioned below are the properties of their respective owners.

### **Legal Disclaimer**

TO THE MAXIMUM EXTENT PERMITTED BY APPLICABLE LAW, THE PRODUCT DESCRIBED, WITH ITS HARDWARE, SOFTWARE AND FIRMWARE, IS PROVIDED “AS IS”, WITH ALL FAULTS AND ERRORS, AND HIKVISION MAKES NO WARRANTIES, EXPRESS OR IMPLIED, INCLUDING WITHOUT LIMITATION, MERCHANTABILITY, SATISFACTORY QUALITY, FITNESS FOR A PARTICULAR PURPOSE, AND NON-INFRINGEMENT OF THIRD PARTY. IN NO EVENT WILL HIKVISION, ITS DIRECTORS, OFFICERS, EMPLOYEES, OR AGENTS BE LIABLE TO YOU FOR ANY SPECIAL, CONSEQUENTIAL, INCIDENTAL, OR INDIRECT DAMAGES, INCLUDING, AMONG OTHERS, DAMAGES FOR LOSS OF BUSINESS PROFITS, BUSINESS INTERRUPTION, OR LOSS OF DATA OR DOCUMENTATION, IN CONNECTION WITH THE USE OF THIS PRODUCT, EVEN IF HIKVISION HAS BEEN ADVISED OF THE POSSIBILITY OF SUCH DAMAGES.

REGARDING TO THE PRODUCT WITH INTERNET ACCESS, THE USE OF PRODUCT SHALL BE WHOLLY AT YOUR OWN RISKS. HIKVISION SHALL NOT TAKE ANY RESPONSIBILITIES FOR ABNORMAL OPERATION, PRIVACY LEAKAGE OR OTHER DAMAGES RESULTING FROM CYBER ATTACK, HACKER ATTACK, VIRUS INSPECTION, OR OTHER INTERNET SECURITY RISKS; HOWEVER, HIKVISION WILL PROVIDE TIMELY TECHNICAL SUPPORT IF REQUIRED.

SURVEILLANCE LAWS VARY BY JURISDICTION. PLEASE CHECK ALL RELEVANT LAWS IN YOUR JURISDICTION BEFORE USING THIS PRODUCT IN ORDER TO ENSURE THAT YOUR USE CONFORMS THE APPLICABLE LAW. HIKVISION SHALL NOT BE LIABLE IN THE EVENT THAT THIS PRODUCT IS USED WITH ILLEGITIMATE PURPOSES.

IN THE EVENT OF ANY CONFLICTS BETWEEN THIS MANUAL AND THE APPLICABLE LAW, THE LATER PREVAILS.

## Regulatory Information

### FCC Information

Please take attention that changes or modification not expressly approved by the party responsible for compliance could void the user's authority to operate the equipment.

**FCC compliance:** This equipment has been tested and found to comply with the limits for a digital device, pursuant to part 15 of the FCC Rules. These limits are designed to provide reasonable protection against harmful interference when the equipment is operated in a commercial environment. This equipment generates, uses, and can radiate radio frequency energy and, if not installed and used in accordance with the instruction manual, may cause harmful interference to radio communications. Operation of this equipment in a residential area is likely to cause harmful interference in which case the user will be required to correct the interference at his own expense.

### FCC Conditions

This device complies with part 15 of the FCC Rules. Operation is subject to the following two conditions:

1. This device may not cause harmful interference.
2. This device must accept any interference received, including interference that may cause undesired operation.

### EU Conformity Statement



This product and - if applicable - the supplied accessories too are marked with "CE" and comply therefore with the applicable harmonized European standards listed under the EMC Directive 2014/30/EU, the LVD Directive 2014/35/EU, the RoHS Directive 2011/65/EU.



2012/19/EU (WEEE directive): Products marked with this symbol cannot be disposed of as unsorted municipal waste in the European Union. For proper recycling, return this product to your local supplier upon the purchase of equivalent new equipment, or dispose of it at designated collection points. For more information see: [www.recyclethis.info](http://www.recyclethis.info).

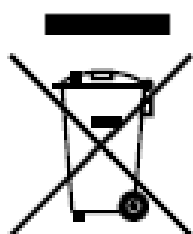



2006/66/EC (battery directive): This product contains a battery that cannot be disposed of as unsorted municipal waste in the European Union. See the product documentation for specific battery information. The battery is marked with this symbol, which may include lettering to indicate cadmium (Cd), lead (Pb), or mercury (Hg). For proper recycling, return the battery to your supplier or to a designated collection point. For more information see: [www.recyclethis.info](http://www.recyclethis.info)

### Industry Canada ICES-003 Compliance

This device meets the CAN ICES-3 (A)/NMB-3(A) standards requirements.

## Symbol Conventions

The symbols that may be found in this document are defined as follows.

Symbol	Description
<i>Note</i>	Provides additional information to emphasize or supplement important points of the main text.
	Indicates a potentially hazardous situation, which if not avoided, could result in equipment damage, data loss, performance degradation, or unexpected results.
	Indicates a hazard with a high level of risk, which if not avoided, will result in death or serious injury.

## Safety Instructions

- Please adopt the power adapter which can meet the safety extra low voltage (SELV) standard. And source with 12 VDC according to the IEC60950-1 and Limited Power Source standard.
- To reduce the risk of fire or electrical shock, do not expose this product to rain or moisture.
- This installation should be made by a qualified service person and should conform to all the local codes.
- Please install blackouts equipment into the power supply circuit for convenient supply interruption.
- Please make sure that the ceiling can support more than 50(N) Newton gravities if the camera is fixed to the ceiling.
- If the product does not work properly, please contact your dealer or the nearest service center. Never attempt to disassemble the camera yourself. (We shall not assume any responsibility for problems caused by unauthorized repair or maintenance.)

## Preventive and Cautionary Tips

- Make sure the power supply voltage is correct before using the camera.
- Do not drop the camera or subject it to physical shock.
- Do not touch sensor modules with fingers. If cleaning is necessary, use a clean cloth with a bit of ethanol and wipe it gently. If the camera will not be used for an extended period of time, put on the lens cap to protect the sensor from dirt.
- Do not aim the camera lens at the strong light such as sun or incandescent lamp. The strong light can cause fatal damage to the camera.
- The sensor may be burned out by a laser beam, so when any laser equipment is being used, make sure that the surface of the sensor not be exposed to the laser

beam.

- Do not place the camera in extremely hot, cold temperatures (the operating temperature should be between  $-30^{\circ}\text{C} \sim 70^{\circ}\text{C}$ ), dusty or damp environment, and do not expose it to high electromagnetic radiation.
- To avoid heat accumulation, good ventilation is required for a proper operating environment.
- Keep the camera away from water and any liquid.
- While shipping, the camera should be packed in its original packing.
- Improper use or replacement of the battery may result in hazard of explosion. Please use the manufacturer recommended battery type.

0402021080620

## Table of Contents

<b>Chapter 1</b>	<b><i>System Requirement</i></b> .....	<b>7</b>
<b>Chapter 2</b>	<b><i>Network Connection</i></b> .....	<b>8</b>
<b>2.1</b>	<b>Wiring over the LAN</b> .....	<b>8</b>
<b>2.2</b>	<b>Activating the Camera</b> .....	<b>9</b>
2.2.1	Activation via Web Browser .....	9
2.2.2	Activation via SADP Software.....	10
<b>Chapter 3</b>	<b><i>Login</i></b> .....	<b>12</b>
<b>Chapter 4</b>	<b><i>Live View</i></b> .....	<b>14</b>
<b>4.1</b>	<b>Live View Page</b> .....	<b>14</b>
<b>4.2</b>	<b>Starting Live View</b> .....	<b>16</b>
<b>4.3</b>	<b>Recording and Capturing Pictures Manually</b> .....	<b>16</b>
<b>4.4</b>	<b>Checking Live Status and Traffic Statistics</b> .....	<b>16</b>
<b>Chapter 5</b>	<b><i>Picture Search</i></b> .....	<b>20</b>
<b>Chapter 6</b>	<b><i>Log Search</i></b> .....	<b>21</b>
<b>Chapter 7</b>	<b><i>Local Configuration</i></b> .....	<b>22</b>
<b>Chapter 8</b>	<b><i>System Configuration</i></b> .....	<b>24</b>
<b>8.1</b>	<b>Viewing Device Information</b> .....	<b>24</b>
<b>8.2</b>	<b>Configuring Installation Parameters</b> .....	<b>24</b>
<b>8.3</b>	<b>Configuring Serial Ports</b> .....	<b>25</b>
<b>8.4</b>	<b>Configuring TCP/IP Settings</b> .....	<b>26</b>
<b>8.5</b>	<b>Configuring Port</b> .....	<b>28</b>
<b>8.6</b>	<b>Configuring HTTPS</b> .....	<b>29</b>
<b>8.7</b>	<b>Configuring Time</b> .....	<b>31</b>
<b>8.8</b>	<b>Enabling User Lock</b> .....	<b>33</b>
<b>Chapter 9</b>	<b><i>Encoding and Storage Configuration</i></b> .....	<b>34</b>
<b>9.1</b>	<b>Configuring Video Encoding</b> .....	<b>34</b>
<b>9.2</b>	<b>Configuring Image Encoding</b> .....	<b>36</b>
<b>9.3</b>	<b>Configuring ROI</b> .....	<b>36</b>
<b>9.4</b>	<b>Configuring Record Schedule</b> .....	<b>38</b>
<b>9.5</b>	<b>Configuring Redundant Storage</b> .....	<b>39</b>
<b>9.6</b>	<b>Configuring FTP</b> .....	<b>40</b>

<b>Chapter 10</b>	<b><i>Text Overlay Configuration</i></b>	<b>44</b>
10.1	Configuring Single Picture Overlay	44
10.2	Configuring Text Overlay on Video	47
<b>Chapter 11</b>	<b><i>Capture Parameters Configuration</i></b>	<b>49</b>
11.1	Configuring License Plate Parameters	49
11.2	Configuring Flash Light Parameters	50
11.3	Configuring Cabinet Parameters	51
<b>Chapter 12</b>	<b><i>Image Parameters Configuration</i></b>	<b>52</b>
12.1	Configuring General Parameters	52
12.2	Configuring Video Image	54
12.3	Configuring Picture	55
12.4	Configuring ICR	56
<b>Chapter 13</b>	<b><i>Application Mode Configuration</i></b>	<b>58</b>
13.1	Smart Mode	58
<b>Chapter 14</b>	<b><i>Exception</i></b>	<b>60</b>
<b>Chapter 15</b>	<b><i>Maintenance</i></b>	<b>61</b>
15.1	Checking Device Status	61
15.2	Managing Users	61
15.2.1	Adding a User	62
15.2.2	Modifying a User	63
15.2.3	Deleting a User	64
15.3	Rebooting the Camera	64
15.4	Restoring Default Settings	65
15.5	Exporting Debug File	65
15.6	Exporting Configuration File	65
15.7	Importing the Configuration File	66
15.8	Upgrading the System	66
<b>Appendix</b>		<b>68</b>
	SADP Software Introduction	68

# Chapter 1 System Requirement

Operating System: Microsoft Windows XP SP1 and above version/Vista/Win 7/Win 10/Server 2003/Server 2008 32bits

CPU: 1.0 GHz or higher

RAM: 1G or higher

Display: 1024×768 resolution or higher

Web Browser: Internet Explorer 8.0 and above version, and Google Chrome 36.



## Chapter 2 Network Connection

**Note:**

- You shall acknowledge that the use of the product with Internet access might be under network security risks. For avoidance of any network attacks and information leakage, please strengthen your own protection. If the product does not work properly, please contact with your dealer or the nearest service center.
- To ensure the network security of the camera, we recommend you to have the camera assessed and maintained termly. You can contact us if you need such service.

**Purpose:**

To view and configure the camera via a LAN, you need to connect the camera in the same subnet with your computer, and install the SADP to search and change the IP address of the camera.

**Note:** For the detailed introduction of SADP, please refer to Appendix.

### 2.1 Wiring over the LAN

The following figures show the two ways of cable connection of a camera and a computer:

**Purpose:**

- To test the camera, you can directly connect the camera to the computer with a network cable as shown in Figure 2-1.
- Refer to the Figure 2-2 to set camera over the LAN via a switch or a router.

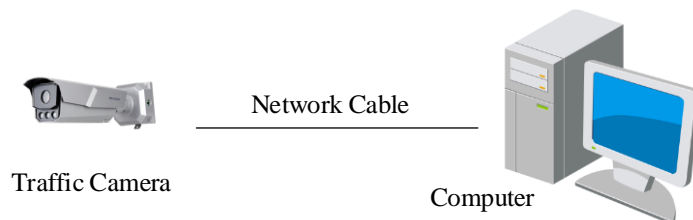

Figure 2-1 Connecting Directly

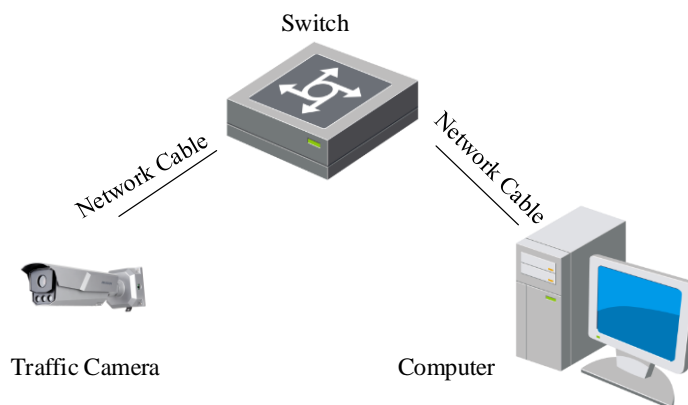

Figure 2-2 Connecting via a Switch or a Router

## 2.2 Activating the Camera

You are required to activate the camera first by setting a strong password for it before you can use the camera.

Activation via Web Browser and Activation via SADP Software are supported.

### 2.2.1 Activation via Web Browser

**Steps:**

1. Power on the camera, and connect the camera to the network.
2. Input the IP address into the address bar of the web browser, and press Enter to enter the activation interface.

The screenshot shows a web browser window titled 'Activate'. It contains three input fields: 'User Name' with the value 'admin', 'Password' (empty), and 'Confirm Password' (empty). Below the password field, there is a note: 'Valid password range [8-16]. You can use a combination of numbers, lowercase, uppercase and special character for your password with at least two kinds of them contained.' An 'OK' button is located at the bottom right of the form.

Figure 2-3 Activation Interface (Web)

3. Create a password and input the password into the password field.



**WARNING**

**STRONG PASSWORD RECOMMENDED**– We highly recommend you create a strong password of your own choosing (using a minimum of 8 characters, including upper case letters, lower case letters, numbers, and special characters) in order to increase the security of your product. And we recommend you reset your password regularly, especially in the high security system, resetting the password monthly or weekly can better protect your product.

4. Confirm the password.
5. Click **OK** to save the password and enter the live view interface.

## 2.2.2 Activation via SADP Software

SADP software is used for detecting the online device, activating the camera, and resetting the password.

Get the SADP software from the official website ([http://www.hikvision.com/cn/download\\_more\\_393.html](http://www.hikvision.com/cn/download_more_393.html)) and install the SADP according to the prompts.

**Steps:**

1. Run the SADP software to search the online devices.
2. Check the device status from the device list, and select the inactive device.

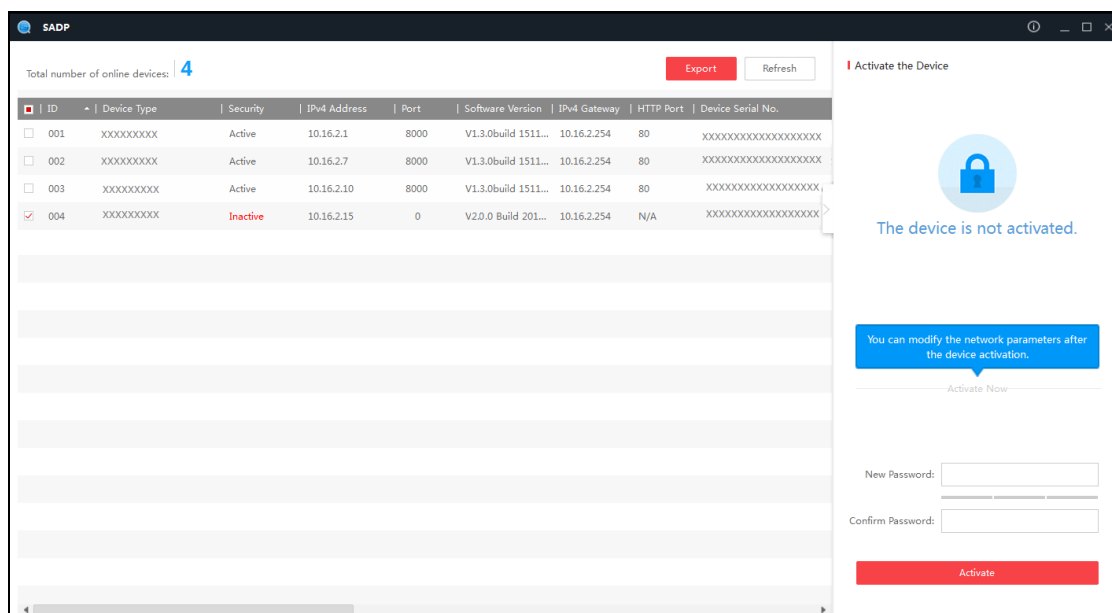

Figure 2-4 SADP Interface

3. Create a password and input the password in the password field, and confirm it.

- Click **Activate** to activate the device.



**STRONG PASSWORD RECOMMENDED**— *We highly recommend you create a strong password of your own choosing (using a minimum of 8 characters, including upper case letters, lower case letters, numbers, and special characters) in order to increase the security of your product. And we recommend you reset your password regularly, especially in the high security system, resetting the password monthly or weekly can better protect your product.*

- Change the device IP address to the same subnet with your computer by either modifying the IP address manually or checking **Enable DHCP**.

**Note:**

DHCP (Dynamic Host Configuration Protocol) is a LAN network protocol using UDP to work.

Modify Network Parameters

Enable DHCP

Device Serial No.: XXXXXXXXXXXX

IP Address: 10.16.2.15

Port: 0

Subnet Mask: 255.255.255.0

Gateway: 10.16.2.254

IPv6 Address:

IPv6 Gateway:

IPv6 Prefix Length: 0

HTTP Port: 0

Security Verification

Admin Password: ●●●●●●

Modify

[Forgot Password](#)

Figure 2-5 Create Password

- Input the password and click **Modify** to activate your IP address modification.

## Chapter 3 Login

*Steps:*

1. Open the web browser.
2. In the browser address bar, input the IP address of the camera, and press the **Enter** key to enter the login interface.
3. Input **User Name** and **Password**.
4. Click **Login**.

The admin user should configure the device accounts and user/operator permissions properly. Delete the unnecessary accounts and user/operator permissions.

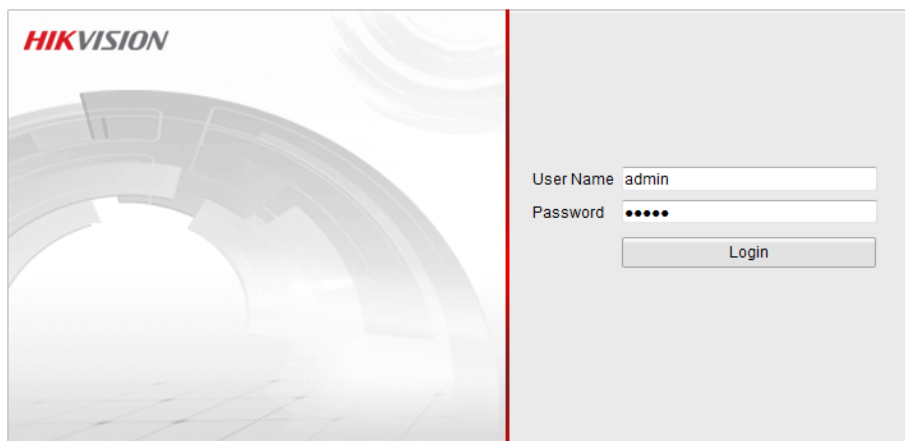

Figure 3-1 Login Interface

5. Install the plug-in before viewing the live video and operating the camera. Please follow the installation prompts to install the plug-in.

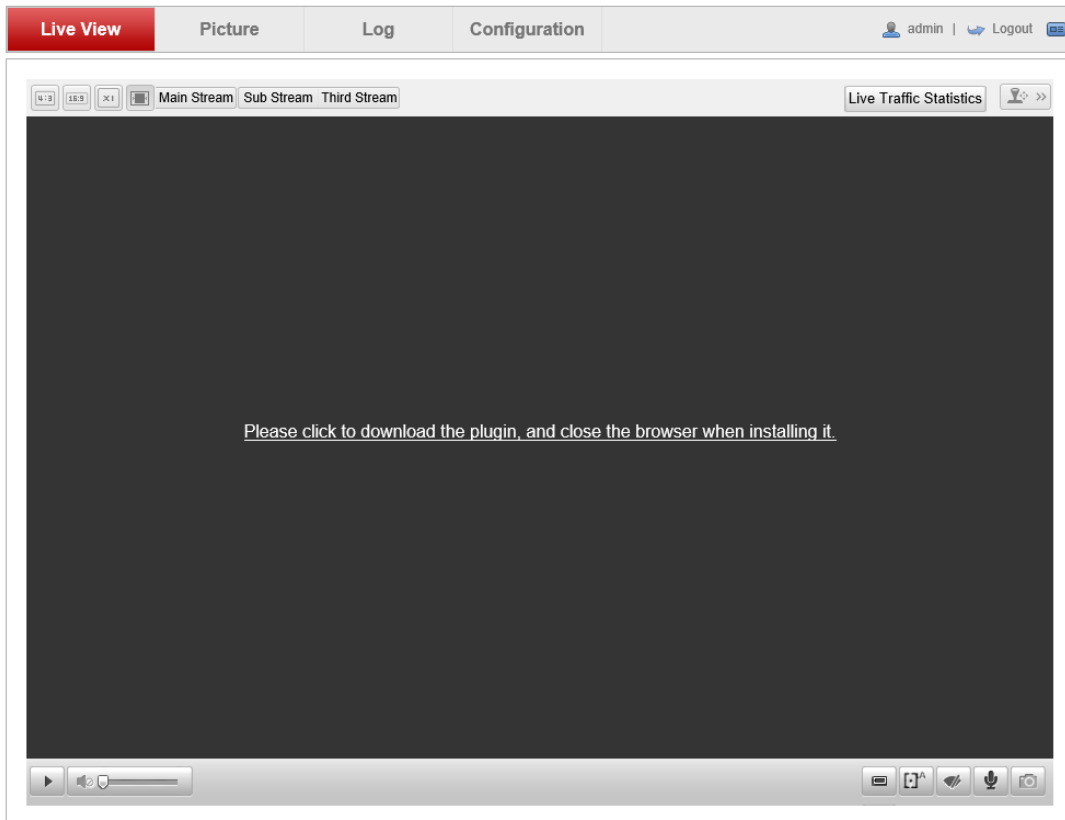

Figure 3-2 Download and Install Plug-in

**Note:** You may have to close the web browser to install the plug-in. Please reopen the web browser and log in again after installing the plug-in.

# Chapter 4 Live View

## 4.1 Live View Page

### *Purpose:*

The live view page allows you to view the real-time video and capture images.

Log in to the camera to enter the live view page, or you can click **Live View** on the menu bar of the main page to enter the live view page.

### **Descriptions of the live view page:**

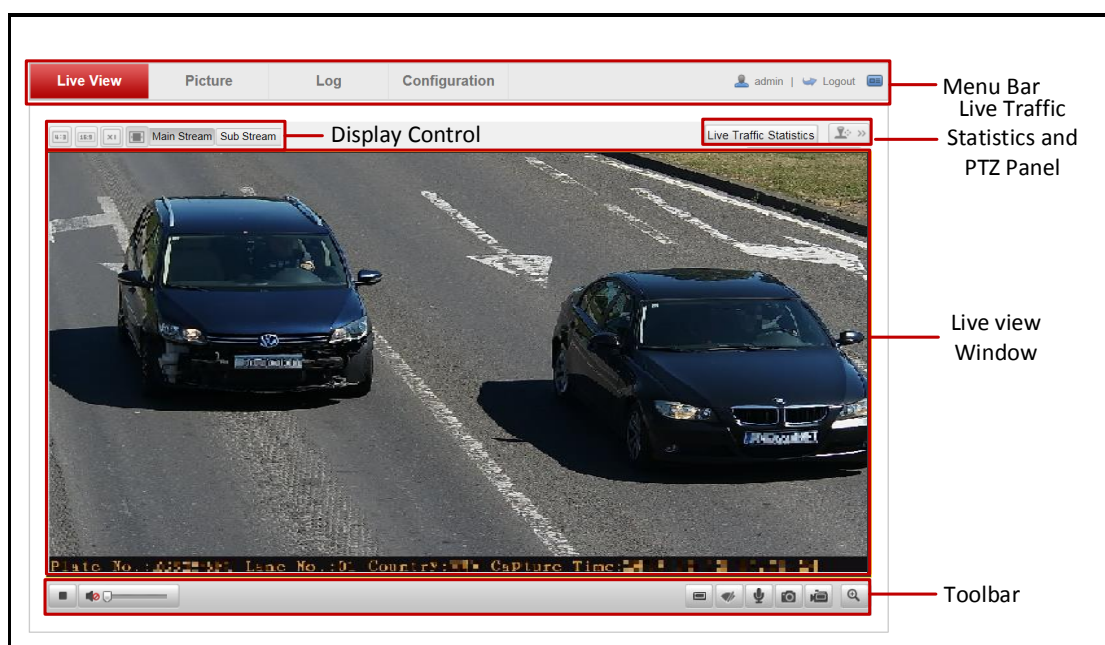



Figure 4-1 Live View Page

### **Menu Bar:**

Click each tab to enter **Live View**, **Picture**, **Log**, and **Configuration** page respectively. Click **Logout** to log out of the system. Click  to view the license.

### **Display Control:**

Click the icons to adjust the layout and the stream type of the live view.

### **Live View Window:**

Display the live video.



















### **Toolbar:**

Operations on the live view page, e.g., start/stop live view, enable/disable audio,

adjust the volume, enable/disable two-way audio, capture, record, enable/disable digital zoom, etc.

Refer to the following table for the description of the icons on the live view page.

Table 4-1 Descriptions of Live View Icons



Icon	Description
	Start/Stop live view.
	The window size is 4:3.
	The window size is 16:9.
	The original window size.
	Self-adaptive window size.
Main Stream	Live view with the main stream.
Sub Stream	Live view with the sub stream.
	Start/Stop audio and adjust the volume.
	Enable/Disable regional focus.
	Enable/Disable two-way audio.
	Manually capture the picture.
	Manually start/stop recording.
	Turn on/off digital zoom function.
Live Traffic Statistics	Enter the live status and traffic statistics page.
	To show/hide PTZ panel.
	Zoom +/zoom -
	Focus +/focus -
	Iris +/iris -
	One-touch focus
	Lens initialization: set the lens to initial settings
	PTZ speed: adjust speed of zoom, focus, and iris change. Higher value means faster speed.
	Click to start wiper. Only applicable to camera that has a wiper.

**Regional focus:** Click  on the tool bar to enter the regional focus operation mode.

Drag the mouse to draw a rectangle on the image as the desired focus region. Click

 to exit the regional focus operation mode.





**Digital zoom:** Click  to enable digital zoom function and the icon turns into .

Then drag the mouse towards low right direction to draw a rectangle on the image as the desired zoom. After viewing it you can click any place of the picture to get back to normal picture.

## 4.2 Starting Live View

On the live view page, click  on the toolbar to start the live view of the camera.

## 4.3 Recording and Capturing Pictures Manually

On the live view page, click  on the toolbar to capture the live pictures or click  to start record. The saving paths of the captured pictures and recorded videos can be set on the **Configuration > Local Configuration** page.

**Note:** The captured image will be saved as JPEG file in your computer.

## 4.4 Checking Live Status and Traffic Statistics

Click **Live Traffic Statistics** on the upper right of the live view window to enter the live status and traffic statistics configuration page.



Figure 4-2 Live Status and Traffic Statistics

As displayed on the figure above, the picture area can be divided into three parts: scene shot area, digital zoom area, license plate area.

- **Arm the camera:** Level 1 Arming, Level 2 Arming, and Disarming are selectable.

- ❖ **Level 1 Arming:** The camera is allowed to connect to only one data storage device for image and information uploading. It is recommended when you develop products, that is, if you use SDK, level 1 arming is the only option.

- ❖ **Level 2 Arming:** The camera is allowed to connect to three data storage devices for image and information uploading.

**Note:** Level 2 Arming is recommended for debugging. Because when the device is running, Level 1 Arming cannot be activated.

- **Measure Plate:** Measure the pixel of the captured license plate. You can click

**Disable** to disable the function.

- **Ruler On:** Enable ruler to measure the length of the captured license plate. You can click Ruler Off to disable the function.
- **Open Folder:** Open the folder that saves the captured pictures.
- **Capture:** Click **Capture** to capture the picture, and the captured pictures will be listed in the Picture List.

No.	Capture Time	Lane No.	Plate Color	License Plate No.	Speed	Illegal Type	Vehicle No.	Directory
20	20171011143359033	2	XXXXX	XXXXXXXXXX	0km/h	XXXXXXXXXX	XXXXX	E:\hxy\traffic_cam\redLight\20171011\
19	20171011143403750	2	XXXXX	XXXXXXXXXX	0km/h	XXXXXXXXXX	XXXXX	E:\hxy\traffic_cam\redLight\20171011\20171011143403750.jpg
18	20171011143400713	2	XXXXX	XXXXXXXXXX	0km/h	XXXXXXXXXX	XXXXX	E:\hxy\traffic_cam\redLight\20171011\20171011143400713.jpg

Figure 4-3 Picture List

Table 4-2 Description of Picture List Parameters

Item	Description
No.	Picture No.
Capture Time	The time of capturing the picture with millisecond precision. For example, 20171011143350933 means the picture is captured at 14:33:50:933, on October 11 <sup>th</sup> , in 2017.
Lane No.	The lane where the vehicle is captured.
Plate Color	The color of the captured license plate. <i>Note:</i> This function is not valid for this camera model.
License Plate No.	The license plate number of the vehicle.
Speed	The speed of the captured vehicle.
Illegal Type	The captured type, normal, wrong-way driving are selectable. <i>Note:</i> Detection of plate color, speed and illegal behavior is not supported for this camera model.
Vehicle No.	The vehicle counting No. ranging from 1 to 65535. It will overwrite if it reaches the max. value.
Directory	The file path of the saved picture.

- **Continuous Capture:** Click **Continuous Capture** to set the parameters including **Lane No.**, **Waiting Time**, **Capture Times**, and **Continuous Capture Interval**.

**Continuous Capture Parameters**

Lane No.  [1-99]

Waiting Time (ms)  [0-2000]

Capture Times  ▼

Continuous Capture Interval --- [0-10000]  
(ms)

Figure 4-4 Set Continuous Capture Parameters

## Chapter 5 Picture Search

### *Purpose:*

The captured picture of all types, including normal, overspeed, wrong-way driving, etc., can be searched from this page. You can also export the pictures to the PC local directory.

### *Before you start:*

Please insert a memory card in the camera for picture storage.

### *Steps:*

1. Click **Picture** on the menu bar to enter picture searching page.

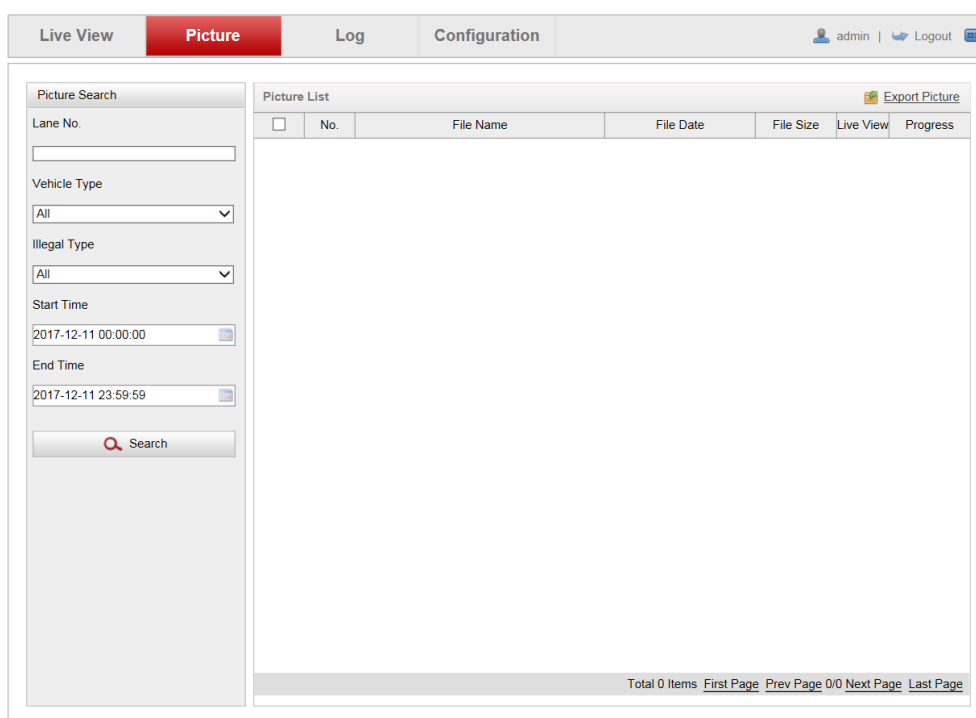

Figure 5-1 Picture Searching

2. Set the picture search conditions to specify the search, including **Lane No.**, **Vehicle Type**, **Illegal Type**, **Start Time**, and **End Time**.
3. Click **Search** to search pictures. The matched pictures will be displayed in **Picture List**.
4. Click **Export Picture** to export the pictures to your PC.

## Chapter 6 Log Search

### *Purpose:*

The operation, alarm, exception and information of the camera can be stored in log files. You can also export the log files on your demand.

### *Before you start:*

Please configure network storage for the camera or insert a memory card in the camera.

### *Steps:*

1. Click **Log** on the menu bar to enter log searching page.

	Time	Major Type	Minor type	Camera No.	Local/Remote U...	Remote Host IP...
1	2015-05-06 00:00:00	Operation	Remote: Login		admin	10.99.107.93
2	2015-05-06 00:00:00	Operation	Remote: Configure Parameters		admin	10.99.107.93
3	2015-05-06 00:00:00	Operation	Remote: Logout		admin	10.99.107.93
4	2015-05-06 00:00:00	Operation	Remote: Login		admin	10.99.107.93
5	2015-05-06 00:00:00	Operation	Remote: Configure Parameters		admin	10.99.107.93
6	2015-05-06 00:00:01	Operation	Remote: Logout		admin	10.99.107.93
7	2015-05-06 00:00:16	Operation	Remote: Login		admin	192.0.0.64
8	2015-05-06 00:00:17	Operation	Remote: Get Parameters		admin	192.0.0.64
9	2015-05-06 00:00:17	Operation	Remote: Logout		admin	192.0.0.64
10	2015-05-06 00:00:18	Operation	Remote: Login		admin	10.99.107.93
11	2015-05-06 00:00:18	Operation	Remote: Get Parameters		admin	10.99.107.93
12	2015-05-06 00:00:18	Operation	Remote: Logout		admin	10.99.107.93
13	2015-05-06 00:00:39	Operation	Remote: Login		admin	10.99.107.93
14	2015-05-06 00:00:39	Operation	Remote: Get Parameters		admin	10.99.107.93
15	2015-05-06 00:00:39	Operation	Remote: Logout		admin	10.99.107.93
16	2015-05-06 00:01:00	Operation	Remote: Login		admin	10.99.107.93
17	2015-05-06 00:01:00	Operation	Remote: Get Parameters		admin	10.99.107.93
18	2015-05-06 00:01:00	Operation	Remote: Logout		admin	10.99.107.93
19	2015-05-06 00:01:21	Operation	Remote: Login		admin	10.99.107.93
20	2015-05-06 00:01:21	Operation	Remote: Get Parameters		admin	10.99.107.93
21	2015-05-06 00:01:21	Operation	Remote: Logout		admin	10.99.107.93
22	2015-05-06 00:01:43	Operation	Remote: Login		admin	10.99.107.93
23	2015-05-06 00:01:43	Operation	Remote: Get Parameters		admin	10.99.107.93
24	2015-05-06 00:01:43	Operation	Remote: Logout		admin	10.99.107.93
25	2015-05-06 00:02:04	Operation	Remote: Login		admin	10.99.107.93

Figure 6-1 Log Searching

2. Set the log search conditions to specify the search, including **Major Type**, **Minor Type**, **Start Time**, and **End Time**.
3. Click **Search** to search log files. The matched log files will be displayed in the list.
4. To export the log files, click **Save** to save the log files in your PC.

## Chapter 7 Local Configuration

### *Purpose:*

You can configure the live view parameters, recording files settings, and picture settings from this page.

### *Note:*

The record files and captured pictures are the ones you record and captured using the web browser and thus the saving paths of them are on the PC running the browser.

Enter the local configuration page: **Configuration > Local Configuration.**

Figure 7-1 Local Configuration

### *Steps:*

1. Configure the following settings:

- **Live View Parameters:** Set the protocol type, live view performance, and rules.

**Protocol Type:** TCP and UDP are selectable.

✧ **TCP:** Ensures complete delivery of streaming data and better video quality, yet the real-time transmission will be affected.

✧ **UDP:** Provides real-time audio and video streams.

**Live View Performance:** Set the live view performance to Real-time, Balanced or Fluent.

**Rules:** Enable or disable rules. If you enable rules, when there is vehicle passing, a tracking frame will appear in the live view.

**Pos Info:** Enable the function, feature information of the detected target is dynamically displayed near the target in the live image.

- **Record File Settings:** Set the manual recorded video parameters.

**Record File Size:** Select the packed size of the manually recorded and downloaded video files to 256M, 512M or 1G. After the selection, the maximum record file size is the value you selected.

**Save record files to:** Set the saving path for the manually recorded video files in the live view page.

- **Picture Settings:** Set the saving path of pictures under the different conditions.

**Save snapshots in live view to:** Set the saving path of the manually captured pictures in live view.

**Save downloaded pictures to:** Set the saving path of the captured pictures in picture search interface.

**Save captured pictures to:** Set the saving path of the captured pictures in the live status and traffic statistic interface.

**Note:** You can click **Browse** to change the directory for saving the videos and pictures.

2. Click **Save** to save the settings.



# Chapter 8 System Configuration

## *Purpose:*

You can configure the parameters on this page, including device information, serial ports, network parameters, time configuration, service, etc.

## 8.1 Viewing Device Information

Go to the device information page to check the device information: **Configuration** > **Device Configuration** > **System Configuration** > **Device Information**.

Device Name and Device No. can be changed as desired.

Other information of the camera, such as Model, Serial No., Firmware Version, Encoding Version, Hardware Version, Number of Channels, Number of Trigger Input, and Number of Trigger Output are displayed for your reference. And the information cannot be edited in this menu.

Device Information	Installation Parameters	Serial Ports	TCP/IP	Port	HTTPS	Time	Traffic Parameters	Service
DST								
<b>Basic Information</b>								
Device Name	<input type="text" value="IP CAPTURE CAMERA"/>							
Device No.	<input type="text" value="88"/>							
Model	IDS-TCM203-A							
Serial No.	IDS-TCM203-A 20180205AI181850201							
Firmware Version	V4.2.2 180423							
Encoding Version	V4.0 build 180420							
Hardware Version	0x433900							
Number of Channels	1							
Number of Trigger Input	2							
Number of Trigger Output	2							

Figure 8-1 Device Information

## 8.2 Configuring Installation Parameters

You can set the installation parameters of the camera. These parameters are designed

for speed detection.

**Steps:**

1. Go to **Configuration > Device Configuration > System Configuration > Installation Parameters.**

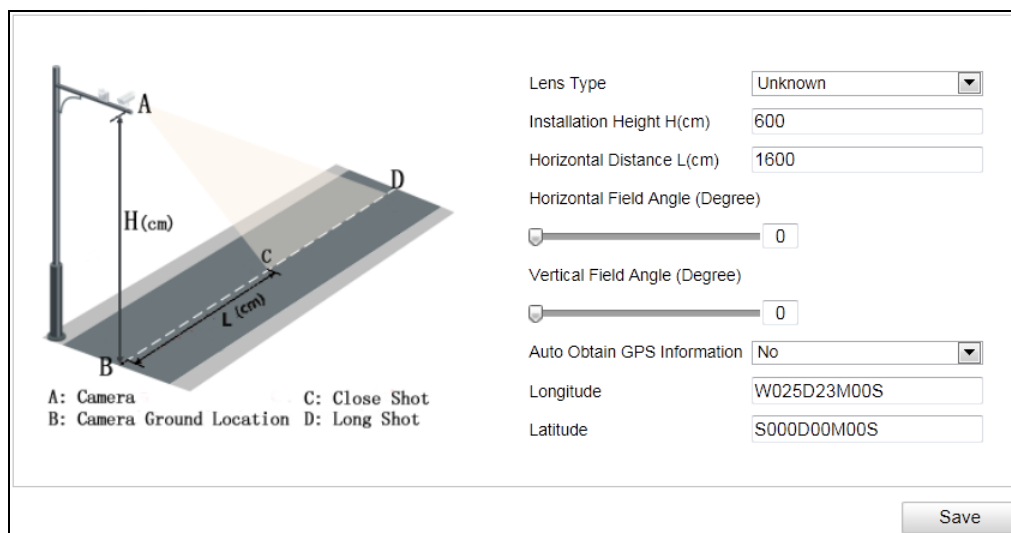

Figure 8-2 Installation Parameters

2. Set the installation parameters according to the actual conditions.  
Installation height and horizontal distance can be set according to the actual installation height.  
Horizontal field angle and vertical field angle refer to the installation angle of the camera. You can set the degrees manually according to the actual installation angle.
3. Click **Save** to save the settings.

## 8.3 Configuring Serial Ports

**Purpose:**

Configure the RS-485 parameters and RS-232 parameters in this page.

- The RS-485 ports are used to input signals related to traffic control. The number of available RS-485 ports can be different according to different camera models.
- The RS-232 port can be used in two ways:
  - **Parameters Configuration:** Connect a computer to the camera through the

serial port. Device parameters can be configured by using software such as HyperTerminal. The serial port parameters must be the same as the serial port parameters of the camera.

- **Transparent Channel:** Connect a serial device directly to the camera. The serial device will be controlled remotely by the computer through the network.

**Steps:**

1. Go to **Configuration > Device Configuration > System Configuration > Serial Ports.**

RS-485 Parameters					
RS-485 No.	Baudrate	Data Bit	Stop Bit	Parity	Flow Control
1	38400	8	1	None	None
2	38400	8	1	None	None

RS-232 Parameters	
Baudrate	115200 bps
Data Bit	8
Stop Bit	1
Parity	None
Flow Control	None
Work Mode	Console

[Advanced Settings](#)

Save

Figure 8-3 Serial Ports Settings

2. Configure the RS-485 and RS-232 parameters.
3. Click **Save** to save the settings.

## 8.4 Configuring TCP/IP Settings

**Purpose:**

TCP/IP settings must be properly configured before you operate the camera over network.

**Steps:**

1. Go to **Configuration > Device Configuration > System Configuration > TCP/IP.**

NIC Settings	
NIC Type	10M/100M/1000M Self-adaptive
<input type="checkbox"/> DHCP	
IPv4 Address	10.10.115.176
IPv4 Subnet Mask	255.255.255.0
IPv4 Default Gateway	10.10.115.254
IPv6 Mode	Auto-Obtain
IPv6 Address	
IPv6 Default Gateway	::
IPv6 Subnet Mask	
MAC Address	94:e1:ac:01:db:a9
MTU	1500
Multicast Address	224.0.0.1
ANPR IP:	0.0.0.0
ANPR Port:	0
Alarm Host Address:	0.0.0.0
Alarm Host Port:	7200
Enable Uploading Picture while Listening:	<input type="checkbox"/>
DNS Server	
Preferred DNS Server	

Figure 8-4 Network Parameters

2. Configure the following parameters.

- **NIC Settings**

Configure the NIC parameters, including the NIC Type, IPv4 Address, IPv4 Subnet Mask, IPv4 Default Gateway, IPv6 Mode, IPv6 Address, IPv6 Subnet Mask, IPv6 Default Gateway, MAC Address (read-only), MTU settings (read-only), Multicast Address, Alarm Management Host Address/Port, ANPR IP address, ANPR port, Alarm Host Address, and Alarm Host Port.

**Notes:**

- The Multicast sends a stream to the multicast group address and allows multiple clients to acquire the stream at the same time by requesting a copy from the multicast group address. Before utilizing this function, you have to enable the Multicast function of your router.
  - Number plate data can be transmitted through ANPR protocol. Before using this function, you have to configure ANPR IP address and ANPR port to connect the host.
- DNS Server Configuration  
DNS (Domain Name System) is a network system used to translate names into IP address.
3. Click **Save** to save the settings.

## 8.5 Configuring Port

### *Purpose:*

Configure the HTTP port, RTSP port, SDK port information on this page.

### *Steps:*

1. Go to **Configuration > Device Configuration > System Configuration > Port.**

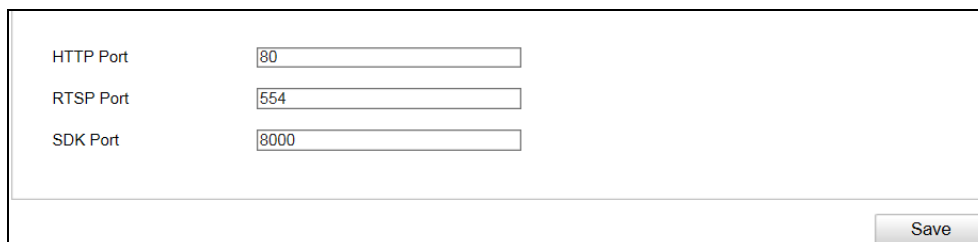

HTTP Port	<input type="text" value="80"/>
RTSP Port	<input type="text" value="554"/>
SDK Port	<input type="text" value="8000"/>

Figure 8-5 Port Configuration

2. Configure the following parameters.
  - **HTTP Port:** The default port number is 80, and it can be changed to any port No. ranges from 1 to 65536 which is not occupied, except 21 (FTP port) and 23 (Telnet port).
  - **RTSP Port:** The default port number is 554 and it can be changed to any port No. ranges from 1 to 65536 which is not occupied, except 21 (FTP port) and 23 (Telnet port).
  - **SDK Port:** The default server port number is 8000, and it can be changed to any

port No. ranges from 2000 to 65535 which is not occupied.

3. Click **Save** to save the settings.

## 8.6 Configuring HTTPS

### *Purpose:*

HTTPS provides authentication of the web site and associated web server that one is communicating with, which protects against Man-in-the-middle attacks. Perform the following steps to set the port number of https.

### *Example*

If you set the port number as 443 and the IP address is 192.168.1.64, you may access the device by inputting `https://192.168.1.64:443` via the web browser.

### *Note:*

The HTTPS port can be only configured through the web browser.

1. Go to **Configuration > Device Configuration > System Configuration > HTTPS**.

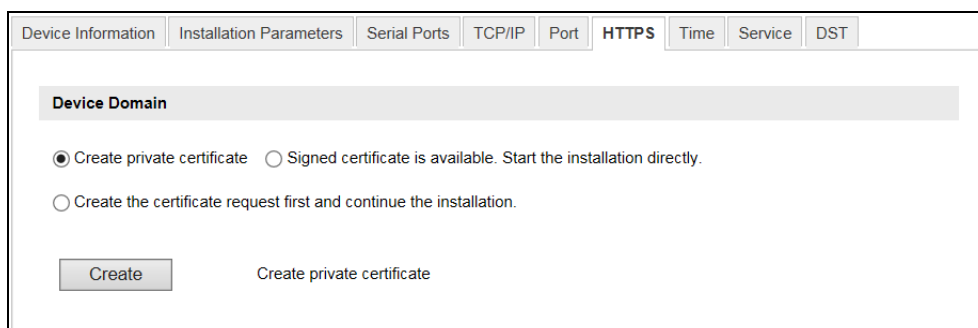

Figure 8-6 HTTPS Configuration

2. Create and install the certificate.

### **OPTION 1:** Create private certificate.

- 1) Click **Create private certificate**.

- 2) Click **Create** and the following message box pops up as below.

The screenshot shows a 'Create' dialog box with the following fields and a tooltip:

- Country:  Wrong country code, like CN.
- Domain Name/IP Address:
- Validity (Day):
- Password:
- State:
- District:
- Organization:
- Unit:
- Email:

Buttons: OK, Cancel

Figure 8-7 Create Private Certificate

- 3) Enter the parameters.
- 4) Click **OK** to save the settings.

**OPTION 2:** Signed certificate is available. Start the installation directly.

- 1) Click **Signed certificate is available. Start the installation directly.**
- 2) Click **View** to find the saving path of the certificate.
- 3) Click **Install** to install the certificate.

**OPTION 3:** Create the certificate request first and continue the installation.

- 1) Click **Create the certificate request first and continue the installation.**
- 2) Click **Create** to create the certificate request.
- 3) Click **Download** to download the certificate request and submit it to the trusted certificate authority for signature.
- 4) After receiving the signed valid certificate, click **View** to find the saving path of the certificate and click **Install** to install it.
- 5) (Optional) Click **Delete** to delete the certificate.

There will be the certificate information after you successfully create and install the certificate.

## 8.7 Configuring Time

You can follow the instructions in this section to configure the time synchronization and DST settings.

- Time Settings

**Steps:**

1. Go to **Configuration > Device Configuration > System Configuration > Time**.
2. Select the time zone of your region.
3. You can adjust time manually. Or you can enable NTP (National Time Protocol) to synchronize time of your camera to the configured NTP server.

- Manual Synchronization

**Steps:**

- 1) Select **Synchronization Mode** as **Manual Synchronization**.
- 2) Check **Device Time**. The grayed out device time shows the current camera time.
- 3) Click  to set the system time from the pop-up calendar.

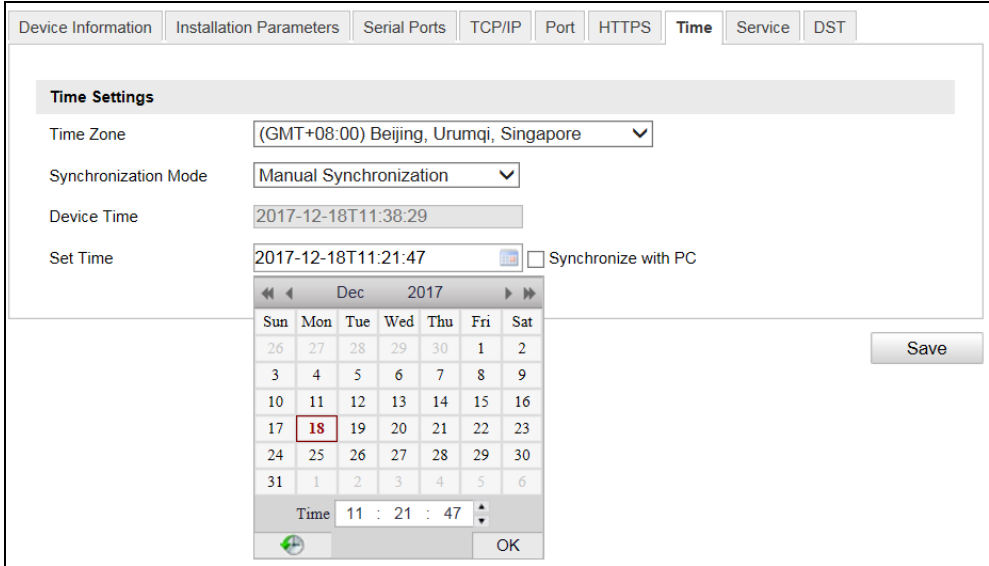

The screenshot shows the 'Time Settings' configuration page. The 'Time Zone' is set to '(GMT+08:00) Beijing, Urumqi, Singapore'. The 'Synchronization Mode' is set to 'Manual Synchronization'. The 'Device Time' is displayed as '2017-12-18T11:38:29'. The 'Set Time' field shows '2017-12-18T11:21:47' with a calendar icon. A pop-up calendar is displayed for December 2017, with the 18th highlighted. Below the calendar is a time picker showing '11 : 21 : 47' and an 'OK' button. A 'Save' button is also visible on the right side of the configuration area.

Figure 8-8 Manual Synchronization

- 4) (Optional) you can also check **Synchronize with PC**. The camera time is synchronized with the time of your computer.
- 5) Click **Save** to save the settings.

- NTP Synchronization



**Steps:**

1. Select **Synchronization Mode** as **NTP Synchronization**.

The screenshot shows a configuration window with the following fields and values:

Field	Value
Time Zone	(GMT+08:00) Beijing, Urumqi, Singapore
Synchronization Mode	NTP Synchronization
Device Time	2017-12-18T13:35:14
Server Address	time.nist.gov
NTP Port	123
Interval	1 Min

Buttons: NTP Test, Save

Figure 8-9 NTP Synchronization

2. Configure the following settings:

**Server Address:** IP address of NTP server.

**NTP Port:** Port of NTP server.

**Interval:** The time interval between the two synchronizing actions with NTP server.

**Note:** If the camera is connected to a public network, you should use a NTP server that has a time synchronization function, such as the server at the National Time Center (IP Address: 210.72.145.44). If the camera is set in a customized network, NTP software can be used to establish a NTP server for time synchronization.

4. Click **Save** to save the settings.
- Configuring DST (Daylight Saving Time)

**Steps:**

1. Go to **Configuration > Device Configuration > System Configuration > DST**.
2. Check **Enable DST**.
3. Set **Start Time**, **End Time**, and **DST Bias**.
4. Click **Save** to save the settings.

Figure 8-10 DST Settings

## 8.8 Enabling User Lock

*Steps:*

1. Go to **Configuration > Device Configuration > System Configuration> Service.**

Figure 8-11 Service Configuration

2. Check **Enable User Lock** to enable the function.
3. Click **Save** to save the settings.

# Chapter 9 Encoding and Storage Configuration

## *Purpose:*

You can configure the encoding and storage related parameters from this page, including video encoding, image encoding, ROI, record schedule, redundant storage, and FTP.

## 9.1 Configuring Video Encoding

### *Steps:*

1. Go to **Configuration > Device Configuration > Encoding and Storage > Video Encoding**.

Video Encoding	
Image Encoding   ROI   Record Schedule   Redundant Storage   FTP	
<b>Main Stream Parameters</b>	
Stream Type	Video&Audio
Max. Bitrate	4096Kbps
Frame Rate	50
Resolution	1920*1080P
SVC	OFF
<a href="#">Advanced Settings</a>	
<b>Sub Stream Parameters</b>	
Stream Type	Video
Max. Bitrate	2048Kbps
Frame Rate	50
Resolution	704*576
SVC	OFF
<a href="#">Advanced Settings</a>	
<input type="button" value="Save"/>	

Figure 9-1 Video Encoding

2. Configure the Main Stream Parameters:

The main stream is usually used for recording and live view with good bandwidth.

**Stream Type:** Video and Video & Audio are selectable.

**Max. Bitrate:** Set the max. bitrate to 32 to 16384 Kbps, or custom. The higher value corresponds to the higher video quality, and the higher bandwidth is required.

**Note:** The maximum limit of the max. bitrate value varies according to different cameras. For some certain cameras, the maximum limit is 8192 Kbps or 12288 Kbps.

**Frame Rate:** The range of frame rate varies according to different video standard. Under NTSC standard, the max. rate can be set to 60 fps. Under PAL standard, the max. rate can be set to 50 fps. The frame rate is to describe the frequency at which the video stream is updated and it is measured by frames per second (fps). A higher frame rate is advantageous when there is movement in the video stream, as it maintains image quality throughout.

**Resolution:** Select the resolution of the video output.

**SVC:** Scalable Video Coding is an extension of the H.264/AVC standard. Select on/off to enable/disable the SVC function.

3. Configure the sub-stream parameters. Sub-stream can be used for live view when the bandwidth is limited.
4. (Optional) Click **Advanced Settings** to expand the menu and configure the following parameters.

**Bitrate Type:** Select the bitrate type to **Constant** or **Variable**.

**Video Quality:** When bitrate type is selected as **Variable**, 6 levels of video quality are selectable.

**Encoding Complexity:** Select the encoding complexity. The higher the complexity is, the better the image quality is.

**I Frame Interval:** Set the I-Frame interval to 1 to 400.

**Video Encoding:** Select the encoding mode to **H.264**, **MJPEG**, or **H.265**.

5. Click **Save** to save the settings.

## 9.2 Configuring Image Encoding

### Steps:

1. Go to **Configuration > Device Configuration > Encoding and Storage > Image Encoding**.

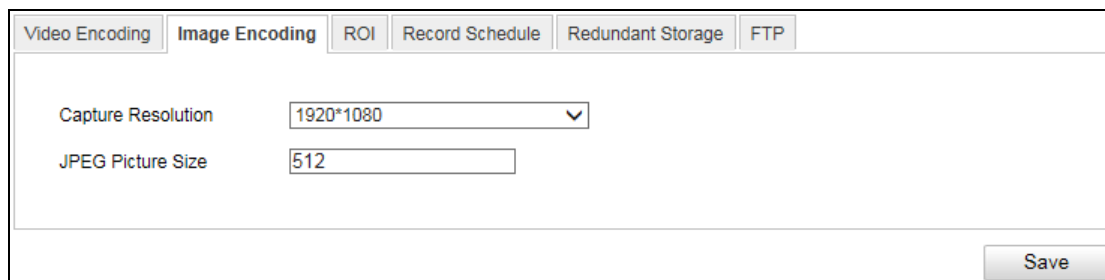

Video Encoding	Image Encoding	ROI	Record Schedule	Redundant Storage	FTP
Capture Resolution	1920*1080				
JPEG Picture Size	512				
Save					

Figure 9-2 Image Encoding

2. Select **Capture Resolution**.
3. Enter **JPEG Picture Size**. The captured pictures are saved as JPEG files, and you can define the picture size by manually entering the value.
4. Click **Save** to save the settings.

## 9.3 Configuring ROI

### Purpose:

ROI (Region of Interest) encoding helps to discriminate the ROI and background information in video compression, which means, the technology assigns more encoding resource to the region of interest, thus to increase the quality of the ROI whereas the background information is less focused.

**Note:** ROI function varies according to different camera models.

### Steps:

1. Go to **Configuration > Device Configuration > Encoding and Storage > ROI**.

Video Encoding | Image Encoding | **ROI** | Record Schedule | Redundant Storage | FTP

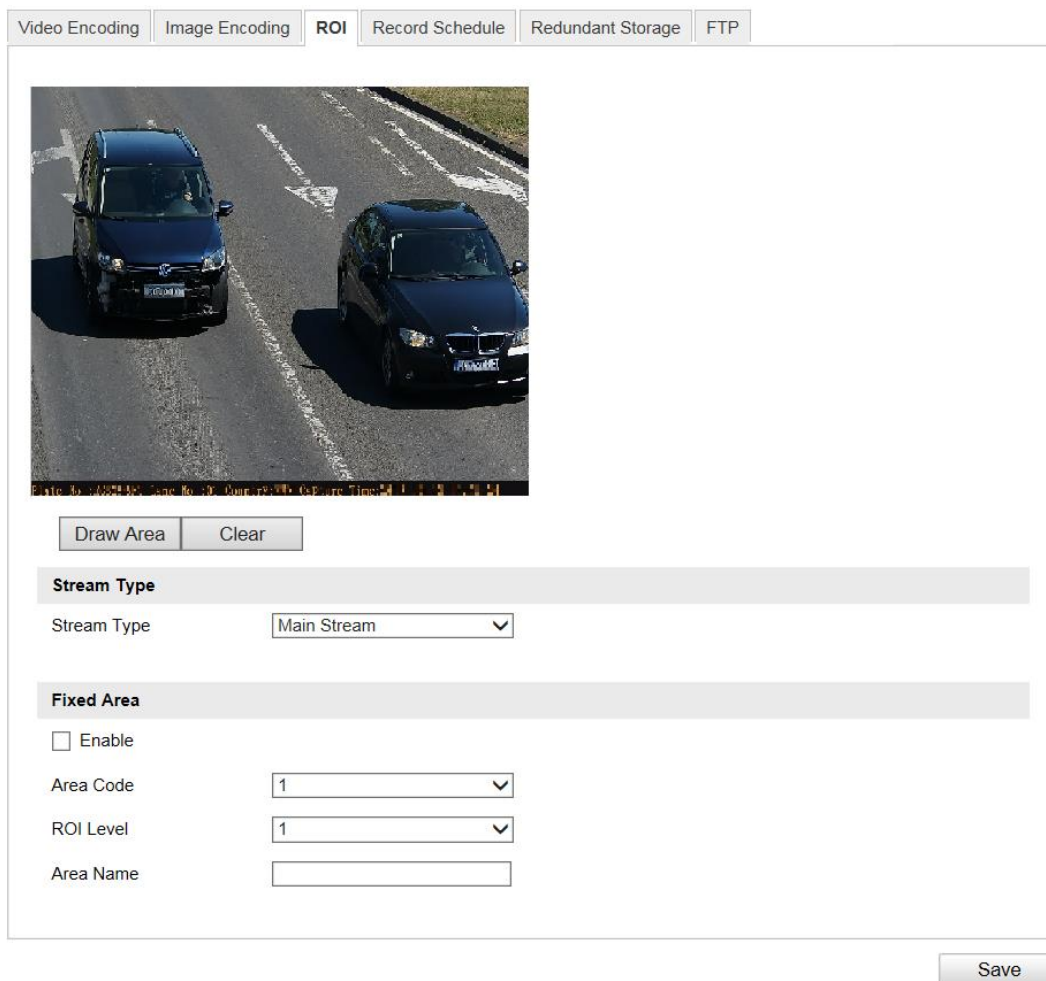

Draw Area Clear

**Stream Type**

Stream Type Main Stream

**Fixed Area**

Enable

Area Code 1

ROI Level 1

Area Name

Save

Figure 9-3 ROI Settings

2. Select **Stream Type** for ROI encoding.  
This camera model supports main stream and sub stream.
3. Check **Enable** under Fixed Area item.
4. Select **Area Code** from the drop-down list for ROI settings. There are four fixed areas selectable.
5. Click **Draw Area**, and then drag the mouse to draw the region of interest on the live video.
6. Select **ROI Level** to set the image quality enhancing level. The larger the value is, the better the image quality is.
7. Enter **Area Name** for ROI as desired.
8. Click **Save** to save the settings.

## 9.4 Configuring Record Schedule

### *Purpose:*

You can follow the instructions to configure the scheduled recording. By default, the record files of scheduled recording are stored in the microSD card. The max. storage space is 128 G.

### *Steps:*

1. Go to **Configuration > Device Configuration > Encoding and Storage > Record Schedule.**

The screenshot displays the 'Record Schedule' configuration page. At the top, there are several tabs: 'Video Encoding', 'Image Encoding', 'ROI', 'Record Schedule' (which is active), 'Redundant Storage', 'FTP', and 'Cloud Storage'. Below the tabs, the 'Record Stream' is set to 'Main Stream'. There are two checked checkboxes: 'Enable Recording Overwriting' and 'Enable Record Schedule'. An 'Edit' button is located to the right of the second checkbox. A grid below shows the days of the week (Mon, Tue, Wed, Thu, Fri, Sat, Sun) and hours (0, 2, 4, 6, 8, 10, 12, 14, 16, 18, 20, 22, 24). A legend indicates 'Normal' recording. A 'Save' button is at the bottom right.

Figure 9-4 Record Schedule Configuration

2. Select **Record Stream**.
3. (Optional) Check **Enable Recording Overwriting**.

If you enable the function, when the storage space is full, the former record files will be overwritten.

If you disable the function, when the storage space is full, the notice that the space is full will be reminded.

4. Check **Enable Record Schedule**.
5. Click **Edit** to edit the record schedule.

**Edit Schedule**

Mon Tue Wed Thu Fri Sat Sun

All Day  Customize

Normal

Period	Start Time	End Time	Record Type
1	00:00	00:00	Normal
2	00:00	00:00	Normal
3	00:00	00:00	Normal
4	00:00	00:00	Normal

Copy to Week  Select All

Mon  Tue  Wed  Thu  Fri  Sat  Sun

Figure 9-5 Edit Record Schedule

- 1) Select the day to set the record schedule.
- 2) Set all-day record or segment record.

If you want to configure the all-day recording, check the **All Day** checkbox.

If you want to record in different time sections, check the **Customize** checkbox. Set the **Start Time** and **End Time**.

**Notes:**

- The time of each segment cannot be overlapped. Up to 4 segments can be configured.
  - The default record type is **Normal** and you cannot edit it.
- 3) Check **Select All** and click **Copy** to copy settings of this day to the whole week. You can also check any of the checkboxes before the date and click **Copy**.
  - 4) Click **OK** to save the settings and exit from the interface.
  6. Click **Save** to save the settings.

## 9.5 Configuring Redundant Storage

**Purpose:**

You can manage the storage, view the HDD information, format the HDD, etc.

**Steps:**

1. Go to **Configuration > Device Configuration > Encoding and Storage >**



## Redundant Storage.

Device List							Format
<input type="checkbox"/>	HDD No.	Capacity	Free Space	Status	Type	Property	Progress
<input type="checkbox"/>	1	7.40GB	6.61GB	Normal	Local	R/W	

Auto-Initialize Redundant Storage  
 Auto-Upload Data in Redundant Storage

### HDD Quota

Picture Capability:  MB  
 Video Capability:  MB  
 Capture Quota Ratio:  %  
 Video Quota Ratio:  %

Save

Figure 9-6 Redundant Storage Configuration

2. View the HDD information such as Capacity, Free Space, Status, etc.
3. (Optional) Check the HDD and click **Format** to format it.
4. (Optional) Check **Auto-Initialize Redundant Storage**. Then the TF card in the redundant storage can be formatted automatically. The storage is used for store captured pictures, traffic violation video, and log.
5. (Optional) Check **Auto-Upload Data in Redundant Storage**.
6. Configure the HDD Quota.
  - 1) Enter the **Capture Quota Ratio**.
  - 2) Enter the **Video Quota Ratio**.

### **Notes:**

- The Capture Quota Ratio ranges from 0 to 100%.
- The sum of Capture Quota Ratio and Video Quota Ratio should be 100%.

## 9.6 Configuring FTP

### **Purpose:**

You can configure the FTP server related information to enable the uploading of the captured pictures to the FTP server.

### **Note:**

We have three ways to storage data (priority ranking from prior to less prior): FTP, SDK arming and local memory card storage. If FTP is enabled, the SDK arming and local memory card storage are invalid. If SDK arming is enabled, memory card storage is invalid.

**Steps:**

1. Go to **Configuration > Device Configuration > Encoding and Storage > FTP.**

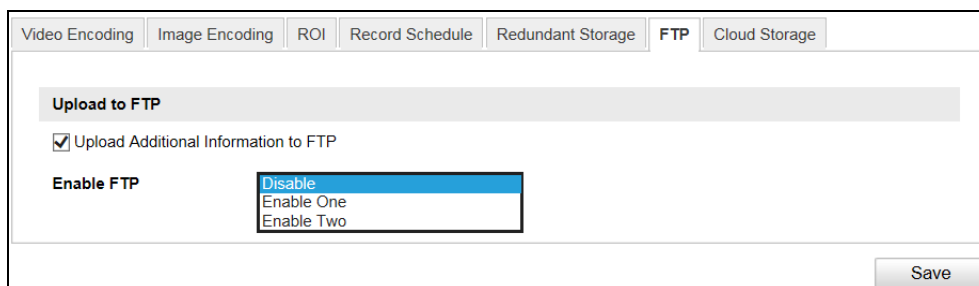

Figure 9-7 FTP Configurations

2. Check **Upload Additional Information to FTP** to enable the uploading function.
3. Select the FTP uploading mode.
  - **Disable:** No data will be uploaded to FTP.
  - **Enable One:** Data can be uploaded to one FTP server.
    - 1) Select **Enable One.**

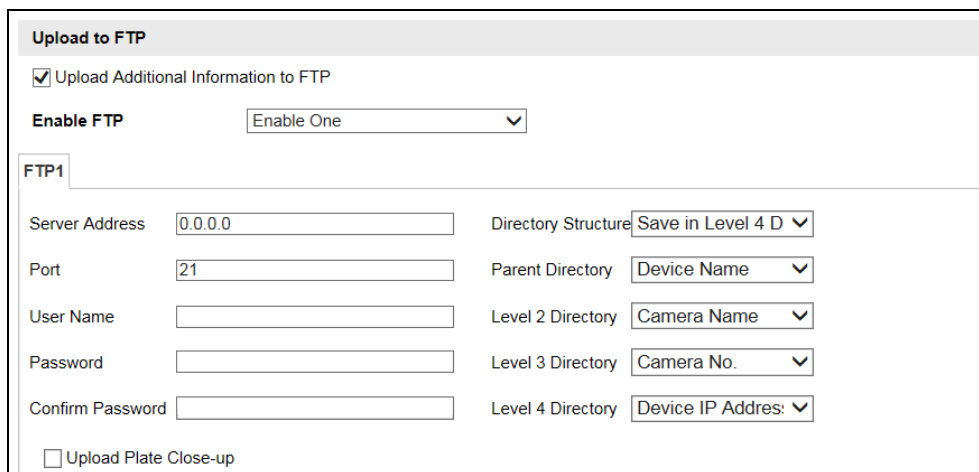

Figure 9-8 Upload to One FTP Server

- 2) Configure the FTP server parameters, including **Server Address**, **Port**, **User Name**, and **Password**.
- 3) Select the **Directory Structure** to save the files. **Save in Root Directory**, **Save in Parent Directory**, and **Save in Level 2/3/4 Directory** are

selectable.

- 4) Select the content in different directories. For the **Parent Directory**, you can select **Device Name**, **Device No.**, and **Device IP Address**. For the **Level 2/3/4 Directory**, you can select **Camera Name**, **Camera No.**, **Device IP Address**, etc.
  - 5) (Optional) Check **Upload Plate Close-up** to upload the close-up of the license plate to the FTP server.
- **Enable Two:** Data can be uploaded to two FTP servers.
    - 1) Select **Enable Two**.

Figure 9-9 Upload to Two FTP Servers

- 2) Select the data type for uploading to FTP 1.
- 3) Select the data type for uploading to FTP 2.



**NOTE**

For the data type, **Checkpoint Data** and **Violation Data** are selectable. If you select **Checkpoint Data** for FTP 1, FTP 2 will receive the **Violation Data** by default.

- 4) Configure the FTP server parameters, including **Server Address**, **Port**, **User Name**, and **Password**.
- 5) Select the **Directory Structure** to save the files. **Save in Root Directory**, **Save in Parent Directory**, and **Save in Level 2/3/4 Directory** are

selectable.

- 6) Select the content in different directories. For the **Parent Directory**, you can select **Device Name**, **Device No.**, and **Device IP Address**. For the **Level 2/3/4 Directory**, you can select **Camera Name**, **Camera No.**, **Device IP Address**, etc.
- 7) (Optional) Check **Upload Plate Close-up** to upload the close-up of the license plate to the FTP server.

4. Configure the **Name Rule**.

- 1) Select the **Separator**.
- 2) Select the **Elements** of each name.

Name Rule		Separator:
No.	Name	Elements
1	Name1	Device IP Address
2	Name2	Time
3	Name3	Vehicle Speed
4	Name4	None
5	Name5	None
6	Name6	None
7	Name7	None
8	Name8	None
9	Name9	None
10	Name10	None
11	Name11	None
12	Name12	None
13	Name13	None
14	Name14	None
15	Name15	None

Figure 9-10 Name Rule Configuration

5. Configure the **OSD Information**.

OSD Information			
Location	<input type="text"/>	Intersection No.	<input type="text"/>
Device No.	<input type="text"/>	Checkpoint 1	<input type="text"/>
Direction No.	<input type="text"/>	Direction	<input type="text"/>

Figure 9-11 OSD Information

6. Click **Save** to save the settings.

# Chapter 10 Text Overlay Configuration

## Purpose:

Configure the OSD on the captured pictures and videos.

## 10.1 Configuring Single Picture Overlay

### Purpose:

You can configure the overlay information of the captured single picture.

### Steps:

1. Go to **Configuration > Device Configuration > Text Overlay > Single Picture Overlay**.

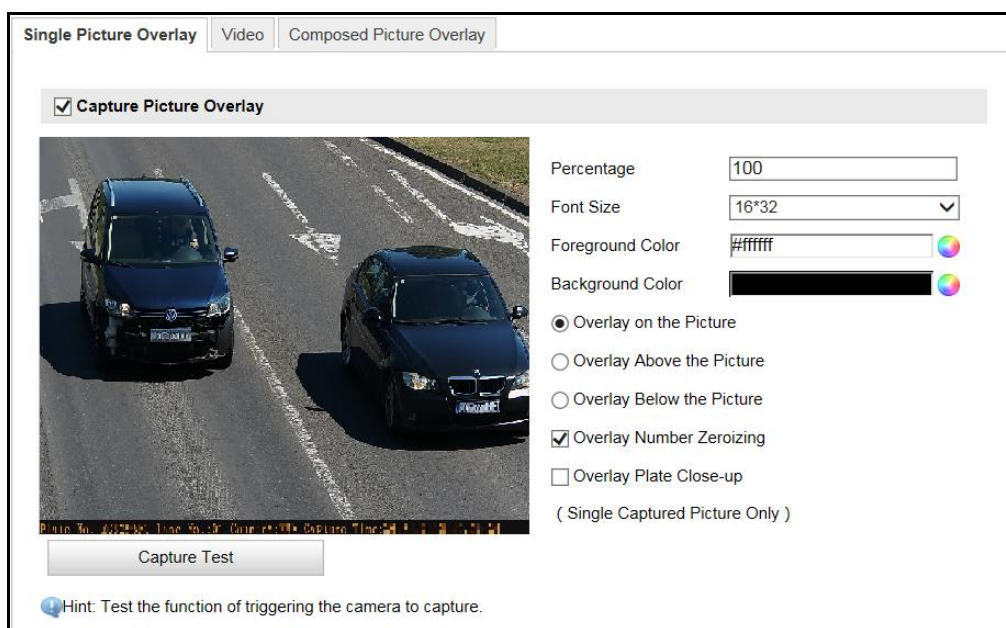

Figure 10-1 Single Picture Overlay

2. Check **Capture Picture Overlay**.
3. Configure the parameters below.
  - **Percentage**: the percentage of the information overlaid on the picture.
  - **Font Size**: the font size of the overlay information.
  - **Foreground Color**: the foreground color of the overlay information.
  - **Background Color**: the background color of the overlay information.

4. Set the overlay text position.

- **Overlay on Picture:** Display the information on the picture.



Figure 10-2 Overlay on Picture

- **Overlay Above the Picture:** Display the information on the top.

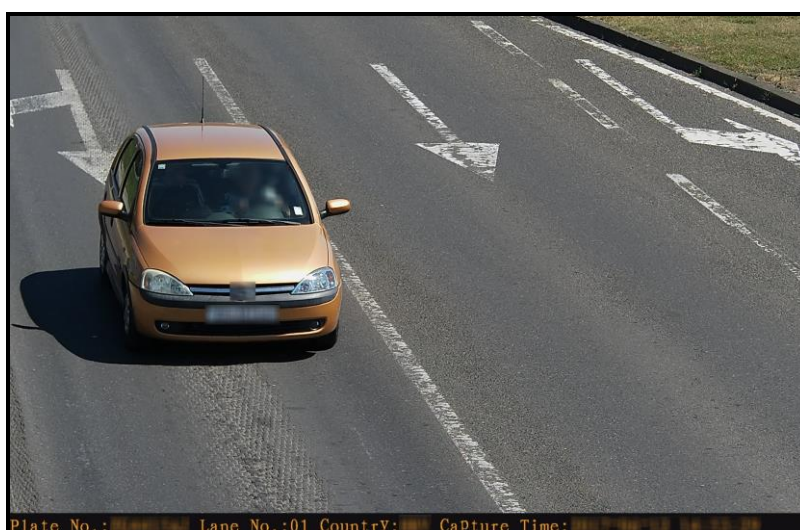

Figure 10-3 Overlay Above the Picture

- **Overlay Below the Picture:** Display the information on the bottom.

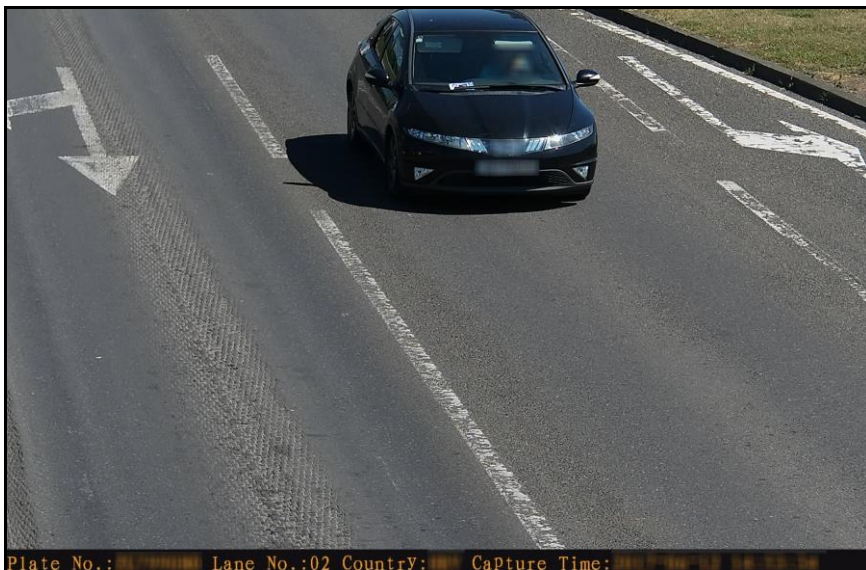





Figure 10-4 Overlay Below the Picture

5. (Optional) Check **Overlay Number Zeroizing**.
6. (Optional) Check **Overlay Plate Close-up** on the captured picture.
7. Configure the overlay information.

Type	Overlay Information	Overlay Position	Space	Line Break Characters
Lane No.:		<input checked="" type="checkbox"/>	0	0
Plate No.:		<input type="checkbox"/>	0	0
Capture Time:	<input checked="" type="checkbox"/> Accurate to milisecond	<input type="checkbox"/>	0	0
Intersection No.:		<input type="checkbox"/>	0	0
Device No.:		<input type="checkbox"/>	0	0

Figure 10-5 Configure Display Information

- 1) Check the overlay information or check **Select All** to display all the overlay information.
- 2) Configure the overlay information.
  - **Overlay Information:** You can edit the details of the overlay information type.
  - **Overlay Position:** For some information you want to display separately, check the checkbox of the desired items. For the other items, they will be displayed together.

- **Space:** It stands for the length of blank space between the last character of the first item and the first character of the next item.
- **Line Break Characters:** When you add Line Break Characters to an item, the item is displayed as a new paragraph, and the number stands for the scale of space above the paragraph.
- / : Click  to move the overlay position up. Click  to move the overlay position down.

E.g., the following picture displays the overlay information.



Figure 10-6 OSD Display

## 10.2 Configuring Text Overlay on Video

### *Purpose:*

You can customize the video OSD on the screen.

### *Steps:*

1. Go to **Configuration > Device Configuration > Text Overlay > Video**.



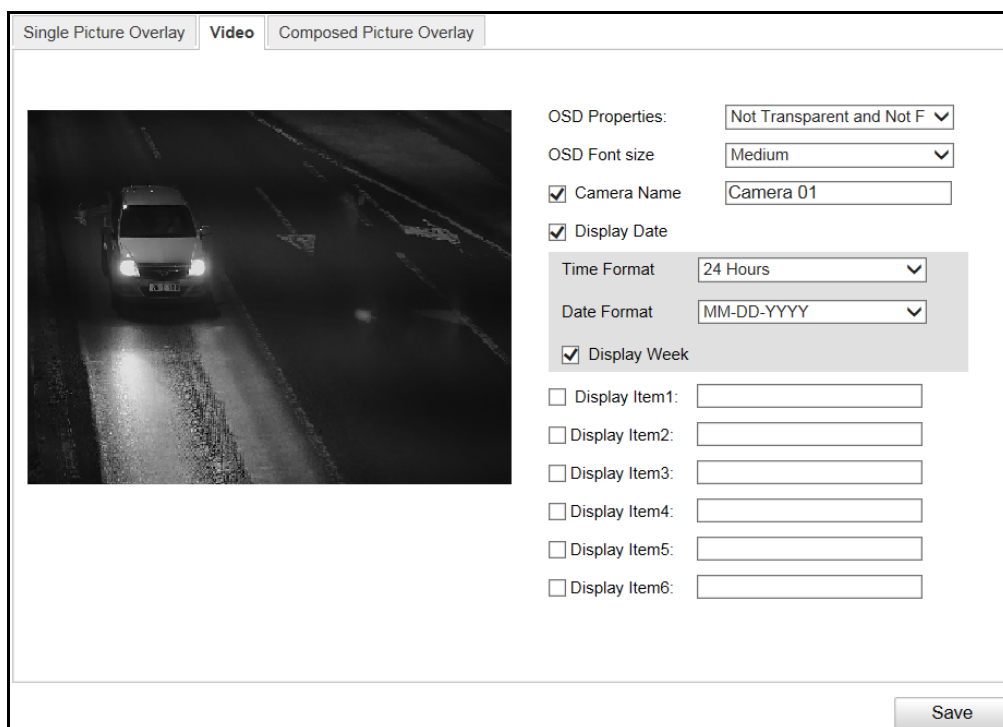

Figure 10-7 OSD on Video

2. Select the **OSD Properties**.
3. Select the **OSD Font Size**.
4. Configure the parameters below according to your needs.
  - Check **Camera Name** and edit the name in the text field.
  - Configure date.
    - 1) Check **Display Date**.
    - 2) Select the **Time Format**.
    - 3) Select the **Date Format**.
    - 4) Check **Display Week**.
    - 5) Check **Display Millisecond**.
  - Check **Display Item** and edit the custom content in the corresponding text fields.
5. Click **Save** to save the settings.

# Chapter 11 Capture Parameters Configuration

## *Purpose:*

You can configure license plate, flash light, traffic light synchronization, image composition, cabinet, and vehicle feature on this page.

## 11.1 Configuring License Plate Parameters

This series of camera supports license plate recognition.

### *Steps:*

1. Go to **Configuration > Device Configuration > Capture Parameters > License Parameters**.

Figure 11-1 License Parameters Configuration

2. Enter the country code in **Country** text field.

Country/region code:

Country/Region	Code	Country/Region	Code
Europe-General	0	France	77
Aland (Finland)	17	Poland	180
Ukraine	230	Greece	91
Switzerland	45	Hungary	102
Spain	70	Macedonia	145
Ireland	104	Bulgaria	24
United Kingdom	79	Czech Republic	58
Netherlands	167	Slovakia	203
Italy	112	Croatia	100
Germany	59	Austria	14

3. Select **License Plate Type**. **Small-Size Plate Recognition** and **Large-Size Plate**

**Recognition** are selectable.

- **Small-Size Plate Recognition:** Select it when the character height of the license plate is in the range of 20 to 30 pixels.
- **Large-Size Plate Recognition:** Select it when the character height of the license plate is in the range of 30 to 40 pixels.

## 11.2 Configuring Flash Light Parameters

*Steps:*

1. Go to **Configuration > Device Configuration > Capture Parameters > Flash Light Parameters**.
2. Select a tab corresponded with the flash light control port.

The camera supports IO:1, IO: 2 and IO:3.

IO:1 is the built-in flash light. IO:2 and IO: 3 are for extra flash lights.

Figure 11-2 Flash Light Parameters Configuration

3. Select **IO Output Mode**. **Constant Light Mode** is available.
  - **Constant Light Mode**
    - 1) Input **Duty Ratio**. It controls the power level of the flash light. 0 means light off, 70 means full-power.
    - 2) Set light on/off control mode. The on/off status can be controlled automatically or on schedule.
      - Auto: Check **Control Constant Light By Brightness**. Set the brightness

threshold.

Schedule: Check **Control Constant Light by Schedule**. Set the start time and end time.

4. (Optional) Copy settings of current port to other ports by checking desired port number.
5. Click **Save** to save the settings.

## 11.3 Configuring Cabinet Parameters

*Steps:*

1. Go to **Configuration > Device Configuration > Capture Parameters > Cabinet Parameters**.

The screenshot displays the 'Cabinet Parameters' configuration page. At the top, there are several tabs: 'License Parameters', 'Flash Light Parameters', 'Traffic Light Synchronization', 'Image Composition', and 'Cabinet Parameters'. Below these tabs is a 'Vehicle Feature' section. The 'Enable Cabinet Alarm' checkbox is checked. The configuration fields are as follows:

Cabinet No.	1
Linkage IO Interface	Disable
Cabinet Name	
Cabinet Opening Status	Low Level
Alarm Upload Interval	30

A 'Save' button is located at the bottom right of the form.

Figure 11-3 Cabinet Parameters Configuration

2. Check **Enable Cabinet Alarm** to enable the function.
3. Configure the parameters including **Cabinet No.**, **Linkage IO Interface**, **Cabinet Name**, **Cabinet Opening Status**, and **Alarm Upload Interval**.
4. Click **Save** to save the settings.

# Chapter 12 Image Parameters Configuration

## *Purpose:*

Configure double shutter parameters, general parameters, video parameters, and ICR on this page.

## 12.1 Configuring General Parameters

### *Purpose:*

General parameters refer to the image parameters applying to both video image and capture image, such as saturation, sensitivity, lens type, sharpness, white balance, gamma correction, and brightness enhancement.

### *Steps:*

1. Go to **Configuration > Device Configuration > Image Parameters > General Parameter.**

Figure 12-1 General Parameters Configuration

2. Set the image saturation, sharpness and white balance mode.

- **Saturation** describes the colorfulness of the image color, which ranges from 0 to 100.
- **Sharpness** describes the edge contrast of the image, which ranges from 1 to 100.
- **White Balance** is the white rendition function of the camera used to adjust the color temperature according to the environment.

The white balance can be set to **Auto WB1**, **Auto WB2**, **Fluorescent Light**, **Incandescent Light**, **Warm Light**, and **Natural Light**.

3. Select WDR mode. **On**, **Time** and **Brightness** are selectable.

Wide Dynamic Range is used when there is a high contrast of the bright area and the dark area of the scene.

**Time:** Activate WDR function on schedule. Set the start time and end time.

**Brightness:** Active WDR function automatically. Set the brightness threshold.

**WDR Level:** higher level means stronger effect.

4. Select **Iris Mode**. **Auto** and **Manual** are selectable.

When you select manual, you can manually adjust camera iris via the iris buttons on live view page.

5. Adjust **Brightness Enhancement at Night**. It ranges from 0 to 100.
6. (Optional) Check **Defog**. You can enable the defog function when the environment is foggy and the image is misty. It enhances the subtle details so that the image appears clearer.
7. (Optional) Check **Light Compensation on License Plate**. Adjust the sensitivity to 0 to 100 if you enable the function.
8. (Optional) Check **Enable Gamma Correction**. And adjust the correction level from 0 to 100.

**Gamma correction** refers to contrast adjustment. This function turns on or adjusts itself according to the change of environment. The higher the correction level is, the more obvious the contrast effect is.

9. (Optional) Click **Capture Test** to test the effects after you complete the adjustment.

## 12.2 Configuring Video Image

### *Purpose:*

The camera supports dual-shutter. One shutter for video image and the other one for capture image. You can configure shutter parameters for video image.

### *Steps:*

1. Go to **Configuration > Device Configuration > Image Parameters > Video.**

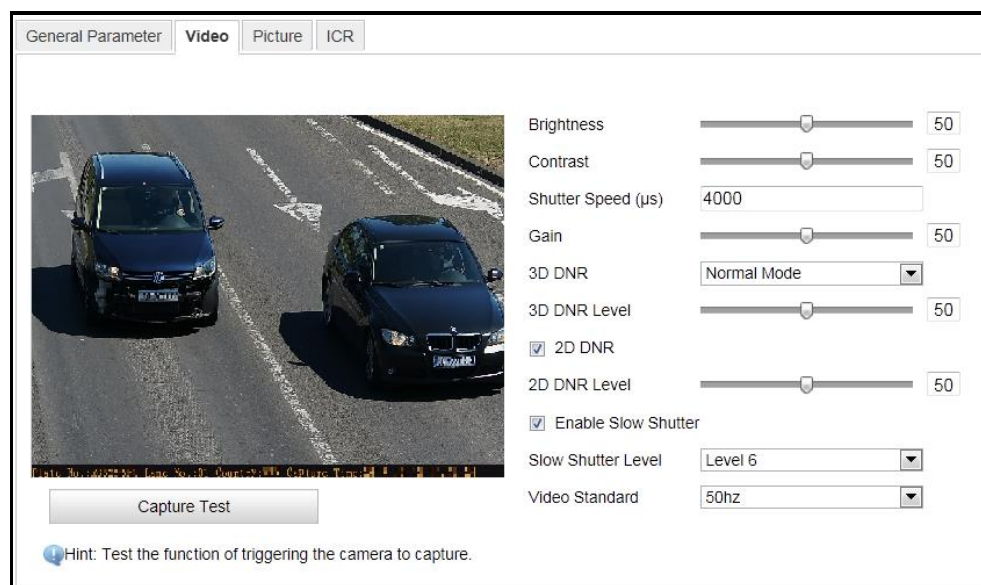

Figure 12-2 Video Image Configuration

2. Adjust **Brightness** [0 to 100].

**Brightness** describes bright of the image, which ranges from 1 to 100.

3. Adjust **Contrast** [0 to 100].

**Contrast** describes the contrast of the image, which ranges from 1 to 100.

4. Enter **Shutter Speed** [80 to 20000  $\mu$ s].

**Shutter speed** describes the length of time when the film or digital sensor inside the camera is exposed to light, also when a camera's shutter is open when taking a photograph. The amount of light that reaches the film or image sensor is proportional to shutter speed.

5. Adjust **Gain** [0 to 100].

**Gain** of image can be manually configured from 0 to 100. The bigger the value is, the brighter would the image be, and the noise would also be amplified to a larger

extent.

6. Select **3D DNR**.
  - 1) If you select **Normal Mode**, adjust **3D DNR Level** from 0 to 100.
  - 2) If you select **Expert Mode**, adjust **Spatial Intensity** and **Time Intensity** from 0 to 100.
7. (Optional) Check **2D DNR**, and adjust **2D DNR Level** from 0 to 100.
8. (Optional) Check **Slow Shutter** and select slow shutter level.

In slow shutter mode, the shutter speed will automatically decrease in low illumination conditions to maintain clear video images by increasing the exposure time. Higher level means lower shutter speed.
9. Select Video Standard, 50Hz and 60Hz are selectable. Choose according to the different video standards; normally 50 Hz for PAL standard and 60 Hz for NTSC standard.
10. (Optional) Click **Capture Test** to test the effects.

## 12.3 Configuring Picture

### *Purpose:*

The camera supports dual-shutter. One shutter for video image and the other one for captured image. You can configure shutter parameters for captured image.

### *Steps:*

1. Go to **Configuration > Device Configuration > Image Parameters > Picture**.



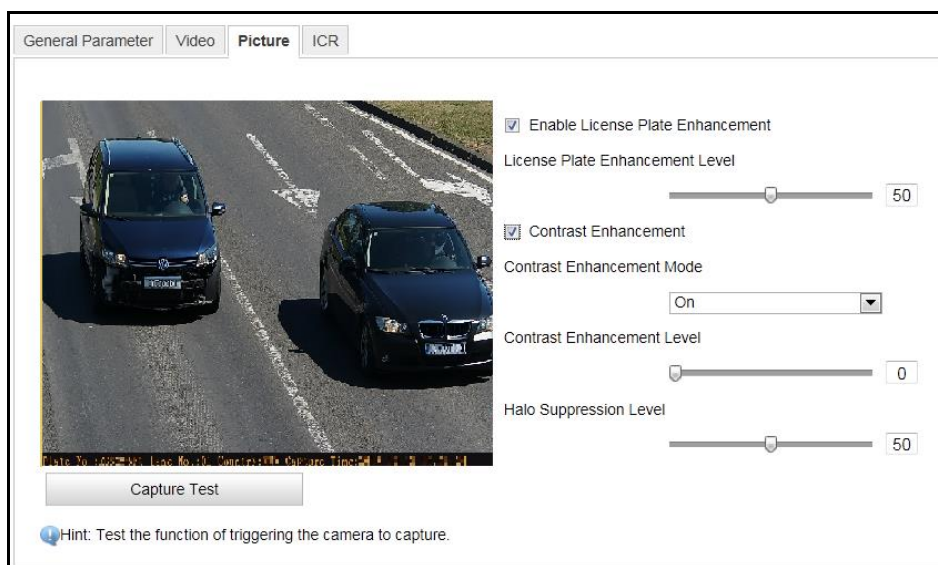

Figure 12-3 Captured Image Configuration

2. Check Enable License Plate Enhancement. Level adjustable from 0 to 100.
3. Check Contrast Enhancement.
  - 1) Select mode as On, Time, Brightness.
    - Time:** Activate the function on schedule. Set the start time and end time.
    - Brightness:** Active the function automatically. Set the brightness threshold.
  - 2) Set enhancement level from 0 to 100. Higher value means stronger effect.
  - 3) Set Halo Suppression Level from 0 to 100. Higher value means stronger effect.

## 12.4 Configuring ICR

### *Purpose:*

IR Cut Filter is used to block or reflect infrared wavelengths but pass visible light. This series of cameras support auto switch of ICR to realize the 24-hour surveillance.

**Note:** ICR configuration is not supported by all camera models of this series.

### *Steps:*

1. Go to **Configuration > Device Configuration > Image Parameters > ICR**.
2. Select **ICR Mode**. **Do not Switch**, **Auto-switch**, **Manual Switch**, and **Scheduled Switch** are selectable.
  - **Do not switch:** The ICR always stays in day mode by default.
  - **Auto Switch:** The ICR switches according to the brightness. Adjust

**Threshold** from 0 to 100.

ICR Mode: Auto-switch

Threshold: 0

Figure 12-4 Auto-Switch

- **Manual Switch:** If you set the ICR mode as Manual Switch, it offers you an option to select day or night.

ICR Mode: Manual Switch

Day/Night Mode: Day

Figure 12-5 Manual Switch

- **Scheduled Switch:** The ICR switches according to the configured time schedule.

No.	Day/Night Mode	Start Time	End Time
1	Day		
2	Day		

Figure 12-6 Scheduled Switch

3. Click **Save** to save the settings.

# Chapter 13 Application Mode Configuration

## *Purpose:*

This chapter introduces the parameters configuration under different trigger mode. The supported trigger modes vary according to the camera models.

**Note:** The following configurations are not supported by all camera models of this series.

## 13.1 Smart Mode

In this mode, target capture and license plate recognition are trigger by internal live video analysis.

Steps:

1. Go to **Configuration > Device Configuration > Application Mode**.
2. Select **Application Mode** as **Smart Mode**.
3. Select **Total Lanes**. Up to 3 lanes are supported.

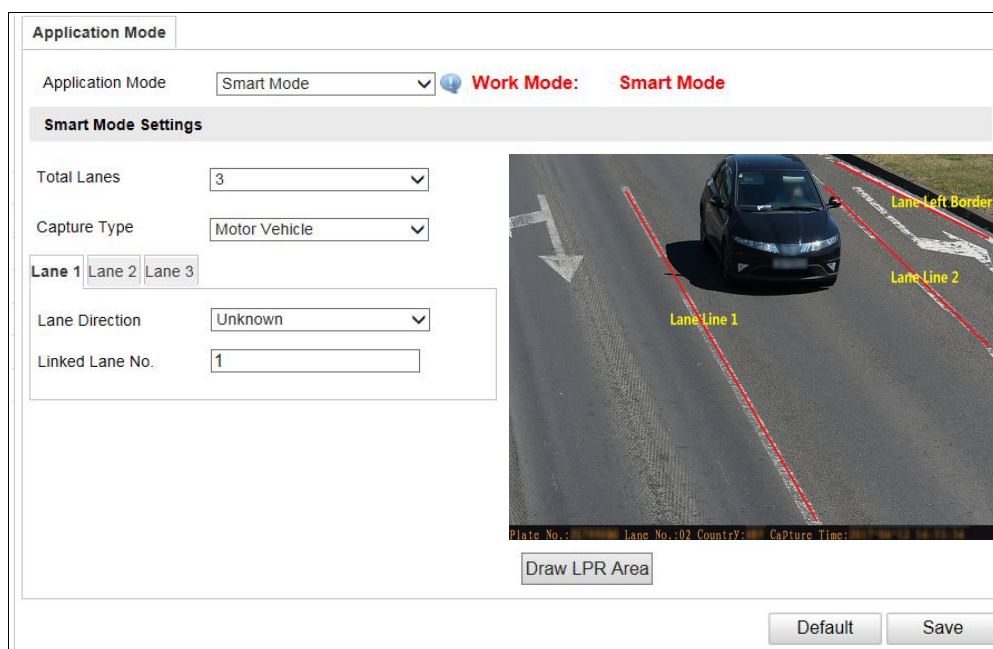

Figure 13-1 Smart Mode Configuration

4. Select Capture Type. All and Motor Vehicle are selectable.

**All:** capture and recognize pedestrian, non-motor vehicle and motor vehicle.

**Motor Vehicle:** capture and recognize motor vehicle.

5. Draw LPR area.

1) Click **Draw LPR Area**.

2) (3 lanes for instance) Adjust the position and length of Lane Line 1, Lane Line 2, Lane Line 3, and Lane Right Border.

**Notes:**

- When drawing lines, you should avoid the overlap among lanes.
- Invalid areas should not be included in the surveillance area.

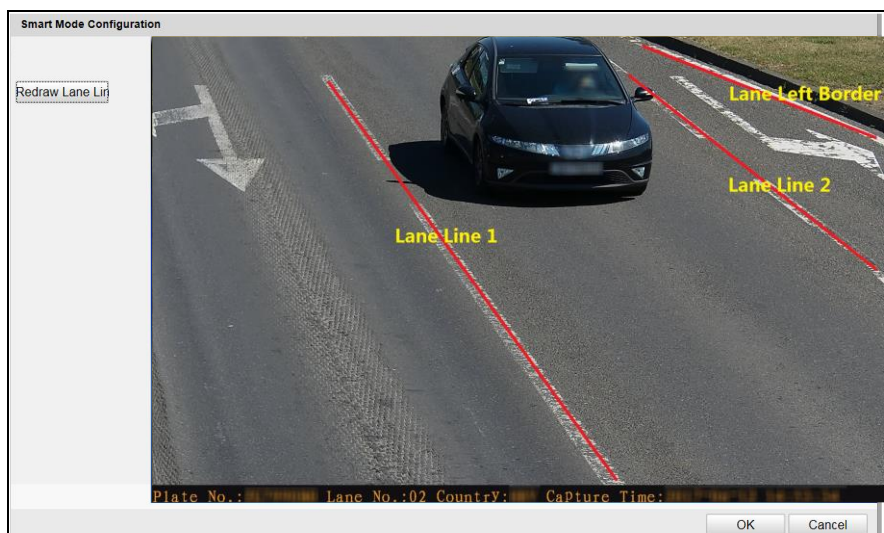

Figure 13-2 Draw LPR Area

3) Save the drawing.

6. Set **Lane Direction** and **Linked Lane No.** for lanes.

## Chapter 14 Exception

### *Purpose:*

The exception type can be HDD error, network disconnected, IP address conflicted, and vehicle detector exception.

### *Steps:*

1. Go to **Configuration > Device Configuration > Exception**.
2. Select the exception type and the corresponding trigger methods.

Enable	Exception Type	Notify Surveillance Center	Trigger Alarm Output	Alarm Dwell Time(s)
<input checked="" type="checkbox"/>	HDD Error	<input checked="" type="checkbox"/>		
<input checked="" type="checkbox"/>	Network Disconnected			
<input checked="" type="checkbox"/>	IP Address Conflicted			
<input checked="" type="checkbox"/>	Vehicle Detector Exception	<input checked="" type="checkbox"/>		

Save

Figure 14-1 Exception Settings

- **Notify Surveillance Center**

Send an exception or alarm signal to remote management software when an event occurs.

- **Trigger Alarm Output**

Trigger one or more external alarm outputs when an event occurs.

- **Alarm Dwell Time(s)**

The waiting time for the alarm triggered. And you can set the alarm dwell time from 0 to 180s.

3. Click **Save** to save the settings.

---

# Chapter 15 Maintenance

## 15.1 Checking Device Status

### *Purpose:*

You can check the device status.

### *Steps:*

1. Go to **Configuration > Device Status**.

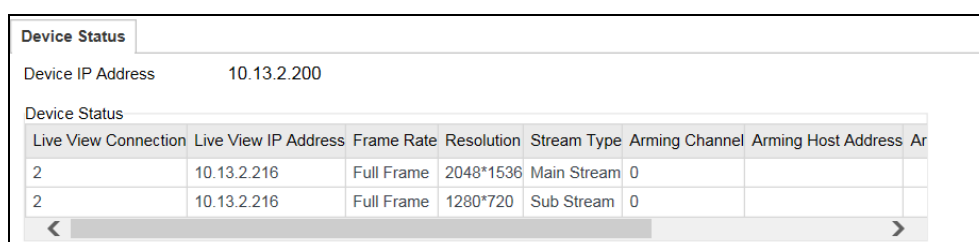

Device Status							
Device IP Address		10.13.2.200					
Device Status							
Live View Connection	Live View IP Address	Frame Rate	Resolution	Stream Type	Arming Channel	Arming Host Address	Arming Level
2	10.13.2.216	Full Frame	2048*1536	Main Stream	0		
2	10.13.2.216	Full Frame	1280*720	Sub Stream	0		

Figure 15-1 Device Status

2. View **Device IP Address** and **Device Status**.
  - **Device IP Address:** Display the current IP address of the camera.
  - **Device Status:** Detailed descriptions are shown in the following table.

Table 15-1 Description of Device Status

Item	Description
Live View Connection	The current number of established live view connection.
Live View IP Address	The IP address of the PC that is viewing the live video.
Arming Channel	The number of channel(s) that armed by arming host(s).
Arming Host Address	The IP address of the host that enables the arming channel.
Arming Level	Arming level 1 and arming level 2 are available. Refer to Section 4.4 for detailed explanation.

## 15.2 Managing Users

The admin user should configure the device accounts and user/operator permissions properly, and delete the unnecessary accounts and user/operator permissions.

Go to **Configuration >Device Configuration> User Management**.

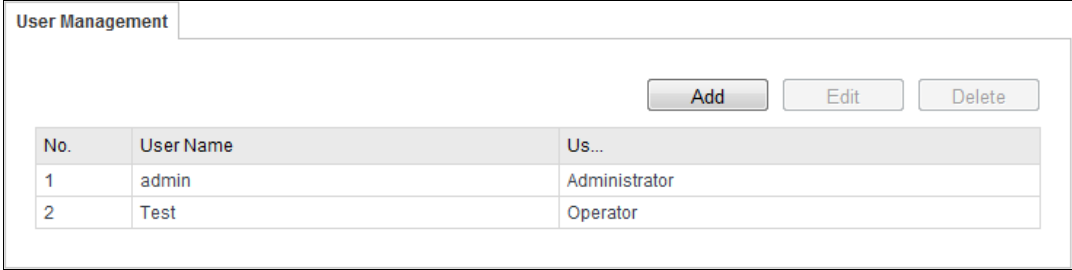

No.	User Name	Us...
1	admin	Administrator
2	Test	Operator

Figure 15-2 User Management

### 15.2.1 Adding a User

The *admin* user has all permissions by default and can create/modify/delete other accounts.

The *admin* user cannot be deleted and you can only change the *admin* password.

#### *Steps:*

1. Click **Add** to add a user.
2. Select **User Type**.
3. Enter **User Name** and **Password**.

 **STRONG PASSWORD RECOMMENDED**– We highly recommend you create a strong password of your own choosing (using a minimum of 8 characters, including at least three of the following categories: upper case letters, lower case letters, numbers, and special characters) in order to increase the security of your product. And we recommend you reset your password regularly, especially in the high security system, resetting the password monthly or weekly can better protect your product.

#### *Notes:*

- Up to 31 user accounts can be created.
  - Users of different levels own different permissions. Operator and user are selectable
4. Confirm the password.
  5. In the **Basic Permission** field and **Camera Permission** field, you can check or

uncheck the permissions for the new user.

6. Click **OK** to add the user.

Add User	
User Name	Test
User Type	Operator
Password	..... <span style="color: green;">✔ Strong</span>
Confirm Password	.....
<span style="color: red;">Valid password range [8~16]. You can use a combination of numbers, lowercase, uppercase and special character for your password with at least two kinds of them contained.</span>	
<b>Basic Permission</b>	<b>Camera Permission</b>
<input type="checkbox"/> Remote Configuration	<input checked="" type="checkbox"/> Remote Live View
<input checked="" type="checkbox"/> Remote Log Search and Status Check	<input checked="" type="checkbox"/> Remote SD Card Access
<input type="checkbox"/> Remote Upgrade and Format	
<input type="checkbox"/> Remote Shutdown and Restart	
<input type="checkbox"/> Remote Request for Alarm Upload, Alarm Output.	
<input type="checkbox"/> Remote Control Local Output	
<input type="checkbox"/> Remote Serial Port Control	
<input type="button" value="OK"/> <input type="button" value="Cancel"/>	

Figure 15-3 Add a User

## 15.2.2 Modifying a User

### Steps:

1. Select a user from the list and click **Edit**.
2. Modify the editable parameters.

Edit User	
User Name	admin
User Type	Administrator
Password	.....
Confirm Password	.....
<span style="color: red;">Valid password range [8~16]. You can use a combination of numbers, lowercase, uppercase and special character for your password with at least two kinds of them contained.</span>	
<b>Basic Permission</b>	<b>Camera Permission</b>
<input checked="" type="checkbox"/> Remote Configuration	<input checked="" type="checkbox"/> Remote Live View
<input checked="" type="checkbox"/> Remote Log Search and Status Check	<input checked="" type="checkbox"/> Remote SD Card Access
<input checked="" type="checkbox"/> Remote Upgrade and Format	
<input checked="" type="checkbox"/> Remote Shutdown and Restart	
<input checked="" type="checkbox"/> Remote Request for Alarm Upload, Alarm Output.	
<input checked="" type="checkbox"/> Remote Control Local Output	
<input checked="" type="checkbox"/> Remote Serial Port Control	
<input type="button" value="OK"/> <input type="button" value="Cancel"/>	



Figure 15-4 Modify Admin

**Edit User**

User Name

User Type

Password

Confirm Password

Valid password range [8~16]. You can use a combination of numbers, lowercase, uppercase and special character for your password with at least two kinds of them contained.

Basic Permission	Camera Permission
<input type="checkbox"/> Remote Configuration	<input checked="" type="checkbox"/> Remote Live View
<input checked="" type="checkbox"/> Remote Log Search and Status Check	<input checked="" type="checkbox"/> Remote SD Card Access
<input type="checkbox"/> Remote Upgrade and Format	
<input type="checkbox"/> Remote Shutdown and Restart	
<input type="checkbox"/> Remote Request for Alarm Upload, Alarm Output.	
<input type="checkbox"/> Remote Control Local Output	
<input type="checkbox"/> Remote Serial Port Control	

OK Cancel

Figure 15-5 Modify Operator/User

3. Click **OK** to save the settings.

### 15.2.3 Deleting a User

*Steps:*

1. Select the user you want to delete and click **Delete**.
2. Click **OK** on the pop-up message box to delete the user.

## 15.3 Rebooting the Camera

*Steps:*

1. Go to **Configuration > Device Configuration > System Maintenance > Reboot**.
2. Click **Reboot** to reboot the camera.

**Reboot**

Reboot Reboot the device.

Figure 15-6 Reboot Device

---

## 15.4 Restoring Default Settings

*Steps:*

1. Go to **Configuration > Device Configuration > Maintenance > Default**.
2. Click **Soft Reset** or **Hard Reset** to restore default settings.

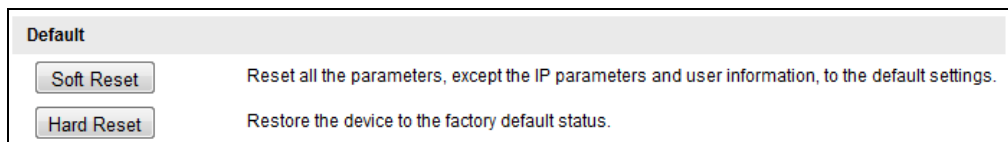

Figure 15-7 Restore Default Settings

**Note:** Use the Hard Reset function with caution.

## 15.5 Exporting Debug File

*Steps:*

1. Go to **Configuration > Device Configuration > Maintenance > Debug File Export**.

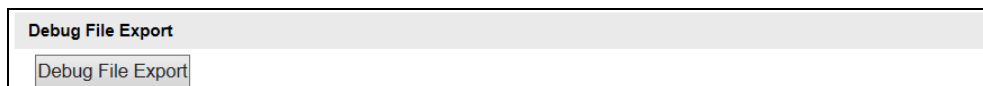

Figure 15-8 Export Debug File

2. Click **Debug File Export** and set the saving path to save the debug file in local storage.

## 15.6 Exporting Configuration File

*Purpose:*

If you have configured a camera and want to use the configured parameters as the example for other cameras, you can export the configuration file to your local PC directory.

*Steps:*

1. Go to **Configuration > Device Configuration > Maintenance > Export Configuration File**.

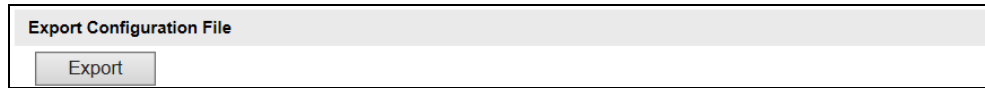

Figure 15-9 Export Configuration File

2. Click **Export** and set the saving path to save the configuration file in local storage.

## 15.7 Importing the Configuration File

### *Purpose:*

Configuration file is used for the batch configuration of the camera, which can simplify the configuration steps when there are a lot of cameras needing configuration.

### *Steps:*

1. Go to **Configuration > Device Configuration > Maintenance > Import Configuration File**.

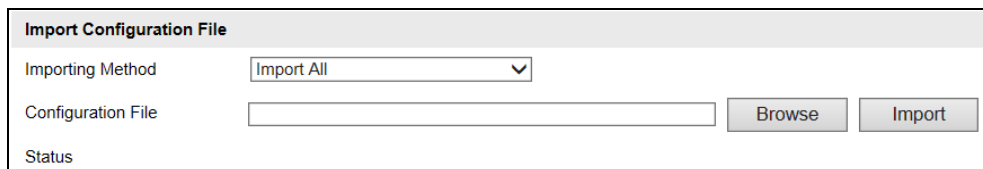

Figure 15-10 Import Configuration File

2. Select **Importing Method**. **Import All** and **Partial Import** are selectable.
3. (Optional) For Partial Import mode, you should select configuration type(s) to import by checking the corresponding checkbox(s).
4. Click **Browse** to select the saved configuration file.
5. Click **Import** to start importing the configuration file.

**Note:** You need to reboot the camera after importing configuration file.

## 15.8 Upgrading the System

### *Steps:*

1. Go to **Configuration > Device Configuration > Maintenance > Upgrade**.

- 
2. Click **Browse** to select the local upgrade file.
  3. Click **Upgrade** to start remote upgrade.

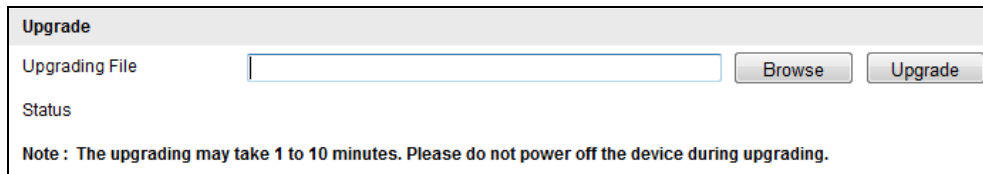

Upgrade

Upgrading File

Status

Note : The upgrading may take 1 to 10 minutes. Please do not power off the device during upgrading.

Figure 15-11 Remote Upgrade

**Note:** The upgrading process will take 1 to 10 minutes. Do not disconnect power of the camera during the process, and the camera reboots automatically after upgrade.

# Appendix

## SADP Software Introduction

### ● Description of SADP

SADP (Search Active Devices Protocol) is a kind of user-friendly and installation-free online device search tool. It searches the active online devices within your subnet and displays the information of the devices. You can also modify the basic network information of the devices using this software.

### ● Search active devices online

#### ◆ Search online devices automatically

After launch the SADP software, it automatically searches the online devices every 15 seconds from the subnet where your computer locates. It displays the total number and information of the searched devices in the Online Devices interface. Device information including the device type, IP address and port number, etc. will be displayed.

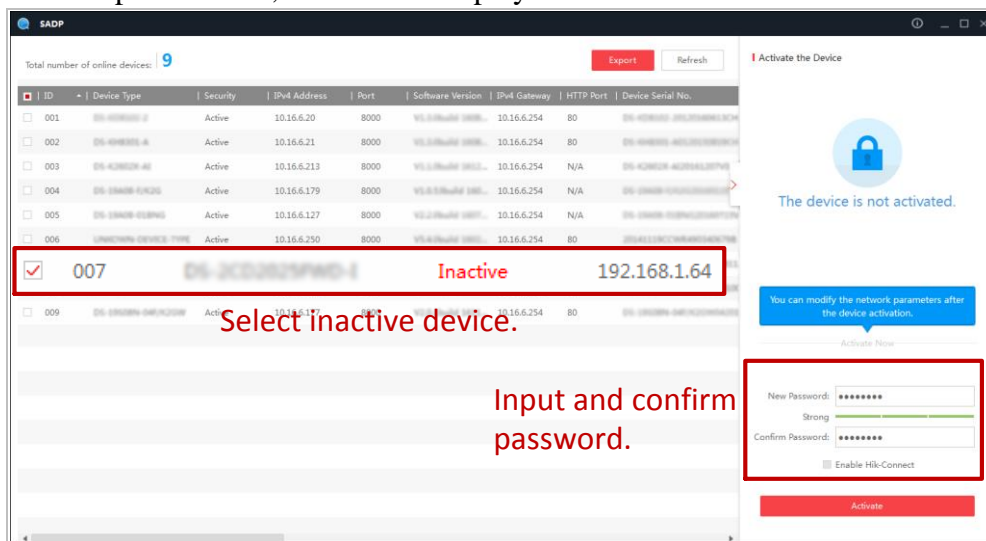
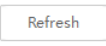

Figure A.1.1 Searching Online Devices



Device can be searched and displayed in the list in 15 seconds after it went online; it will be removed from the list in 45 seconds after it went offline.



#### ◆ Search online devices manually

You can also click  to refresh the online device list manually. The newly searched devices will be added to the list.



You can click  or  on each column heading to order the information;

---

you can click  to expand the device table and hide the network parameter panel on the right side, or click  to show the network parameter panel.

## ● **Modify network parameters**

### *Steps:*

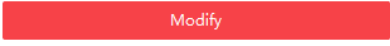
1. Select the device to be modified in the device list and the network parameters of the device will be displayed in the **Modify Network Parameters** panel on the right side.
2. Edit the modifiable network parameters, e.g. IP address and port number.
3. Enter the password of the admin account of the device in the **Password** field and click  to save the changes.



- *For your privacy and to better protect your system against security risks, we strongly recommend the use of strong passwords for all functions and network devices. The password should be something of your own choosing (using a minimum of 8 characters, including upper case letters, lower case letters, numbers and special characters) in order to increase the security of your product.*
- *Proper configuration of all passwords and other security settings is the responsibility of the installer and/or end-user.*

**Modify Network Parameters**

Enable DHCP

Device Serial No.:

IP Address:

Port:

Subnet Mask:

Gateway:

IPv6 Address:

IPv6 Gateway:

IPv6 Prefix Length:

HTTP Port:

---

Security Verification

Admin Password:

[Modify](#)

[Forgot Password](#)

Figure A.1.2 Modify Network Parameters



See Far, Go Further