



## High Mount Outdoor Detector HX-40/40AM/ 40DAM

# INSTALLATION INSTRUCTIONS



HX-40	2 PIRs standard model
HX-40AM	HX-40 with anti-masking
HX-40DAM	HX-40AM with micro-wave



- 3.0 m high mount detection area (12.0 m)
- Unique pyro element
- Intelligent AND logic
- Dual signal processing logic
- Vegetation sway analysis logic
- Ideal detection area setting
- Digital anti-masking (AM/DAM model only)
- Microwave range selector (DAM model only)

## CONTENTS

1	INSTALLATION PRECAUTIONS.....	2
1-1	BEFORE INSTALLATION.....	2
1-2	PARTS IDENTIFICATION.....	3
1-3	KNOCKOUTS.....	4
1-4	DETECTION AREA.....	5
1-5	DETERMINATION OF PIR DETECTION LENGTH.....	5
2	INSTALLATION.....	6
2-1	MOUNTING WITH BRACKET.....	6
2-2	ADJUSTING THE VERTICAL ANGLE.....	8
2-3	MOUNTING WITHOUT BRACKET.....	9
2-4	WIRING.....	10
2-5	WALL TAMPER (OPTION).....	11
3	WALK TEST.....	12
4	SETTING.....	13
5	AREA ADJUSTMENT.....	16
6	LED INDICATION.....	17
7	SPECIFICATIONS.....	18
7-1	SPECIFICATIONS.....	18
7-2	DIMENSIONS.....	19

# 1 INSTALLATION PRECAUTIONS

## 1-1 BEFORE INSTALLATION

 <b>Warning</b>	Failure to follow the instructions provided with this indication and improper handling may cause death or serious injury.
 <b>Caution</b>	Failure to follow the instructions provided with this indication and improper handling may cause injury and/or property damage.

The check  mark indicates recommendation.

The nix  sign indicates prohibition.

 <b>Warning</b>	 <b>Warning</b>	 <b>Caution</b>
 <p>Do not repair or modify product</p>	 <p>Keep product away from water</p>	 <p>Mount the unit securely</p>

Mounting height

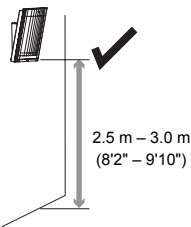

Keep the detector parallel to the ground.

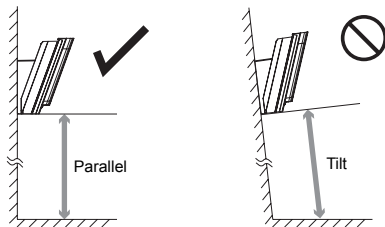

Consider the direction a person is approaching from, as well as the detection area.



Install the detector in a place where it is free from false alarm factors. For example:

• Sunlight and reflection

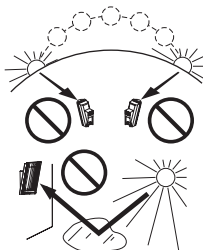

• Heat source

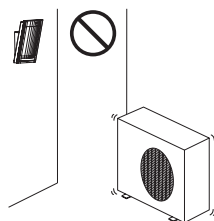

• Objects moving in the wind

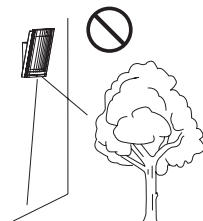

## -Precautions for installing two or more sensors

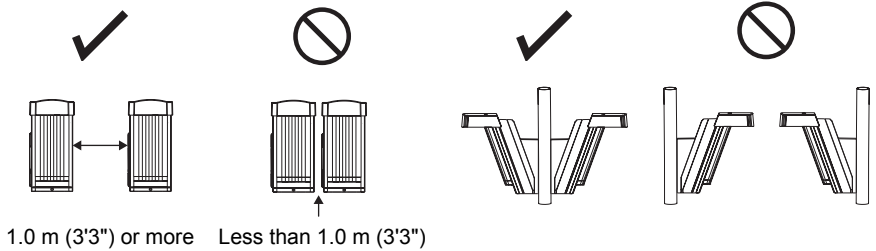

Do not install two or more HX-40DAM's units side-by-side or face-to-face. Instead, install them back-to-back. If mounting on the same wall, be sure they are at least 1.0 m (3'3") apart from each other.

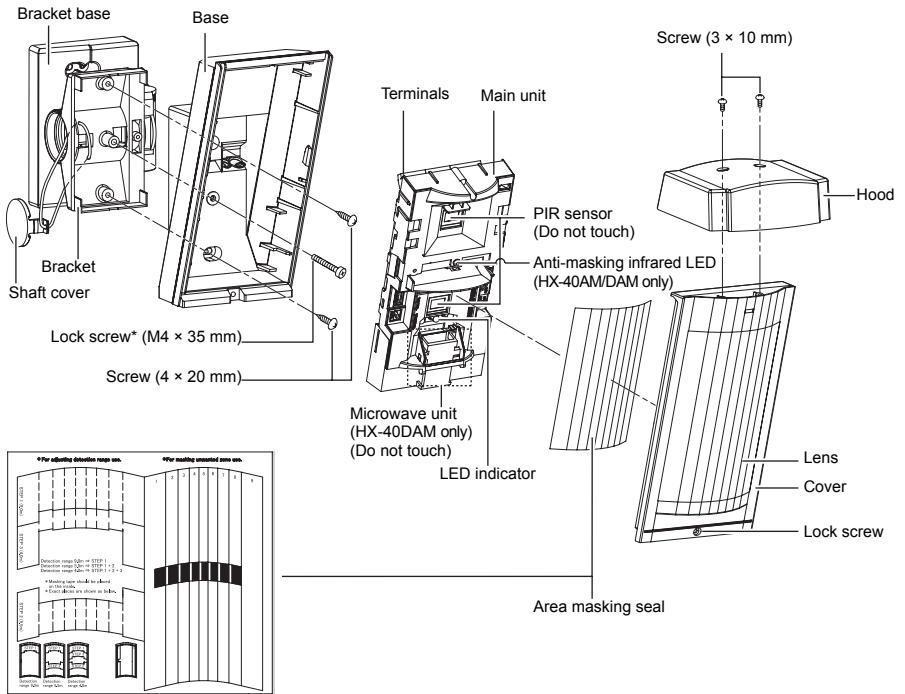

## 1-2 PARTS IDENTIFICATION



### Screw kit

For joint	For wall mounting	For hood
Screw (4 x 20 mm)	Screw (4 x 20 mm)	Screw (3 x 10 mm)
		

\*Lock screw attached on bracket base

**Main unit**

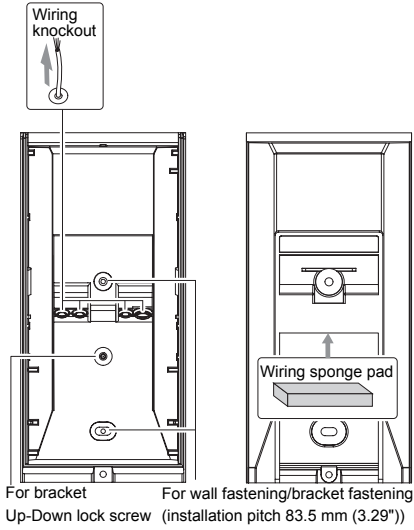

**Bracket**

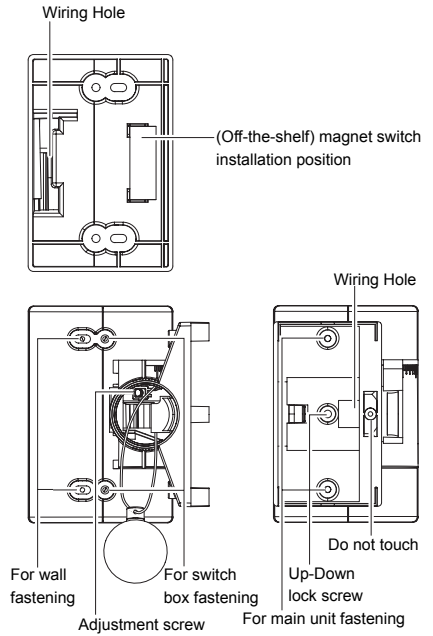

## 1-4 DETECTION AREA

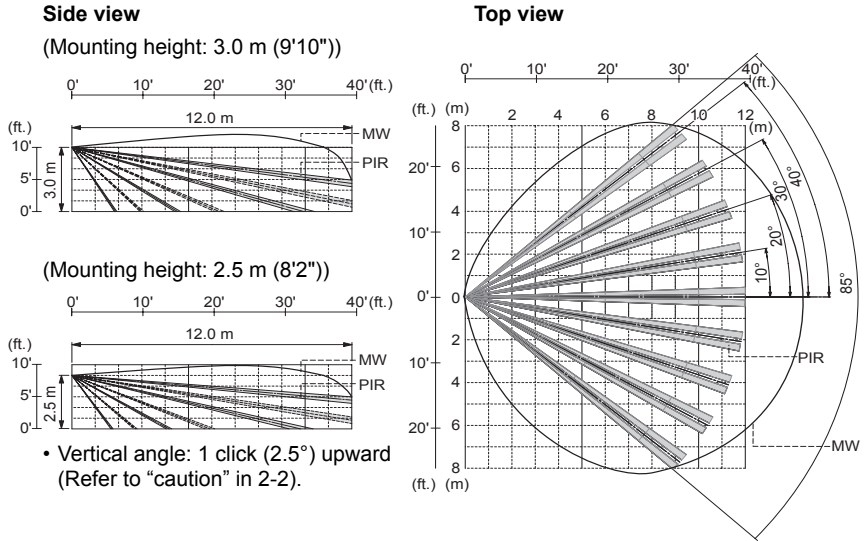

## 1-5 DETERMINATION OF PIR DETECTION LENGTH

To adjust the detection length, apply the masking seals to the back of the lens according to the required detection length. Three types of masking seals are provided. Combine them according to the detection length required.

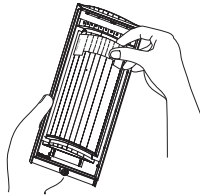

Apply masking seal directly on the back side of the lens.

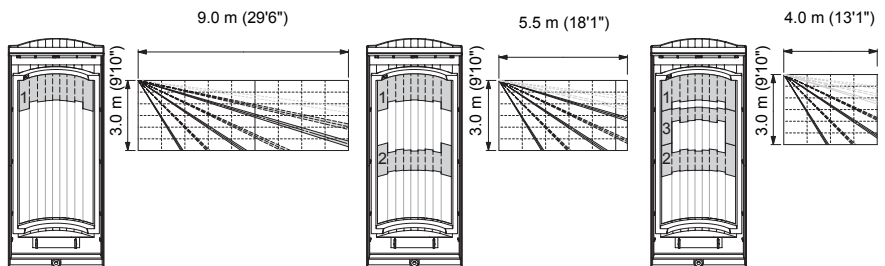

For microwave detection setting please refer to "4 SETTING".

# 2

## INSTALLATION

Use the bracket for normal installation. The unit may be mounted directly on the wall, without the bracket, only if the following three conditions are not;

- The mounting height 3.0 m (9'10").
- Horizontal direction adjustment is unnecessary.
- The ground is level.

### 2-1 MOUNTING WITH BRACKET

Using the bracket makes it possible to adjust the unit horizontally by  $\pm 90^\circ$ .  
In cases where the ground is uneven and/or not parallel with the base of the unit, it is possible to adjust the unit vertically by  $\pm 20^\circ$ .

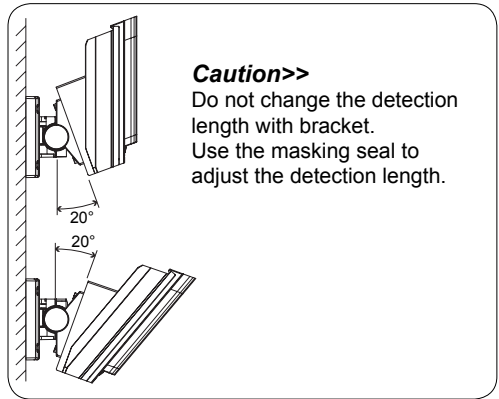
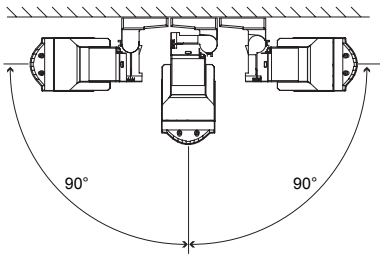

- 1 Remove the Up-Down lock screw.

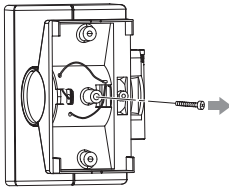

- 2 Push the shaft cover clip straightforwardly with your thumb. In case the clip is stuck, use a suitable tool. e.g. back side of a screw driver.

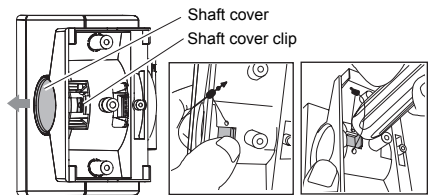

- 3 Loosen the adjustment screw two turns.

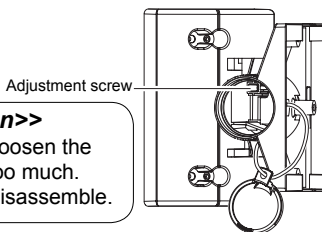

**Caution>>**

Do not loosen the screw too much.  
It may disassemble.

- 4 Tilt the bracket about  $45^\circ$  and pass through the wire.

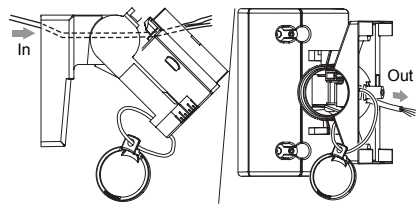

- 5 Determine the horizontal direction (left or right) of the detector before installing the bracket on the wall.

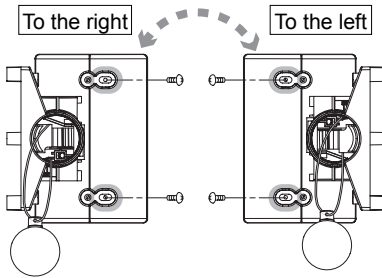

- 6 Open the wiring knockout.

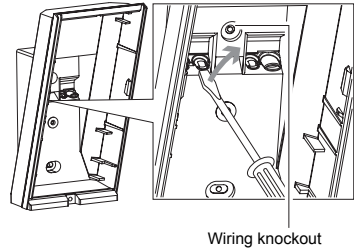

- 7 Open the Up-Down lock screw knockout for connecting the bracket.

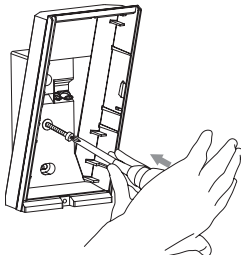

Knockout with 4 × 20 tapping screw (screwkit)

- 8 Tighten screws ① and ②, adjust the bracket angle (refer to 2-2), then tighten screw ③. Perform an area check. If re-adjustment is required, loosen screw ③ and change the bracket angle. After the adjustment is complete, tighten screw ③ again.

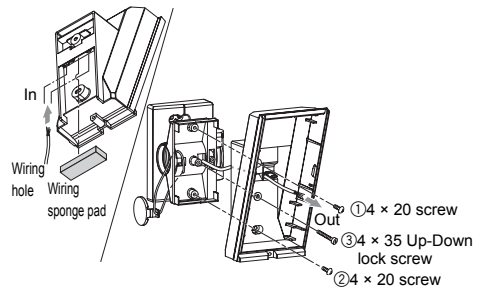

- 9 Tighten the adjustment screw clockwise.

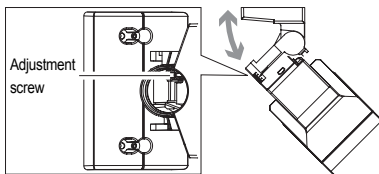

- 10 Wire to the terminal and install the main unit and lens on the base.

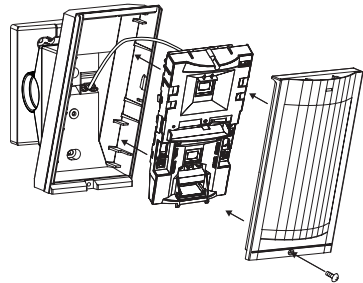

- 11 Install the shaft cover into place.

## 2-2 ADJUSTING THE VERTICAL ANGLE

For best performance, install detector parallel to the ground.

Decide the detection length. If you choose 9.0 m/5.5 m/4.0 m, mask the unnecessary lens with masking seals. Refer to the 1-5 for the details.

Perform the walk test to check if detector is parallel to the ground.

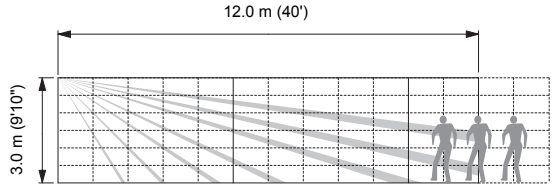

\* This is the case to have 12 m detection length.

If the detection length is shorter than the designated one (refer to page 5), change the detector angle upward.

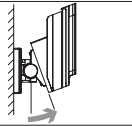

If the detection length is longer than the designated one (refer to page 5), change the detector angle downward.

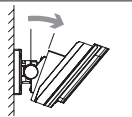

If the detection length is equal to the designated one, adjustments have been completed.

### Caution>>

If the base of the unit is already parallel to the ground,

- Do not change the detection length by tilting the unit up or down. Detection length should be adjusted with masking seal. Refer to 1-5 and 2-1 for the details.

Example (the ground is level)

0° is the right setting for 3.0 m (9'10") height installation.

Adjust 1 click (2.5° upward) for 2.5 m (8'2") height installation.

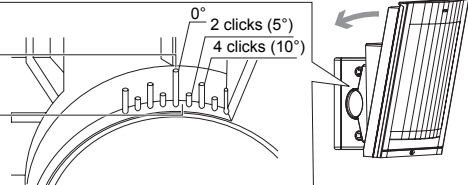



## 2-3 MOUNTING WITHOUT BRACKET

- 1 Open the wiring knockout with suitable tool e.g. screwdriver.

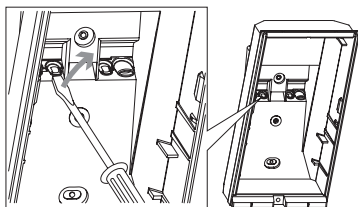

- 2 Pull the wire through the base knockout.

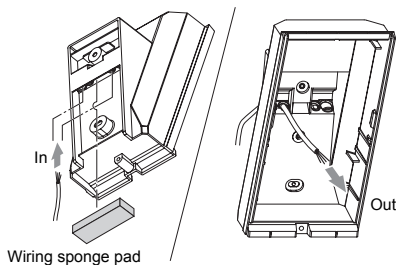

- 3 Fasten the base to the wall.

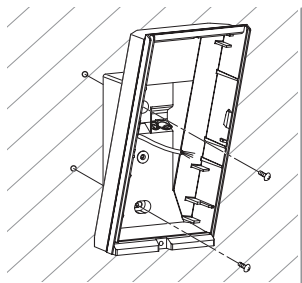

- 4 Install main unit after wiring to the terminal.

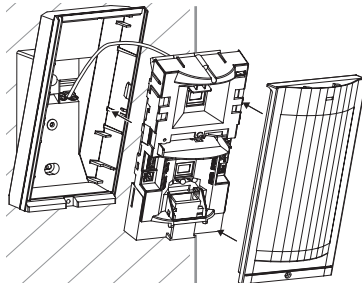

## 2-4 WIRING

Power wires should not exceed the following lengths.

WIRE GAUGE	HX-40		HX-40AM		HX-40DAM	
	12 V	14 V	12 V	14 V	12 V	14 V
AWG22 (0.33 mm <sup>2</sup> )	160 m (520')	360 m (1,180')	140 m (460')	310 m (1,020')	120 m (390')	250 m (820')
AWG20 (0.52 mm <sup>2</sup> )	260 m (850')	560 m (1,840')	230 m (750')	490 m (1,610')	180 m (590')	390 m (1,280')
AWG18 (0.83 mm <sup>2</sup> )	410 m (1,350')	900 m (2,950')	360 m (1,180')	780 m (2,560')	290 m (950')	630 m (2,070')

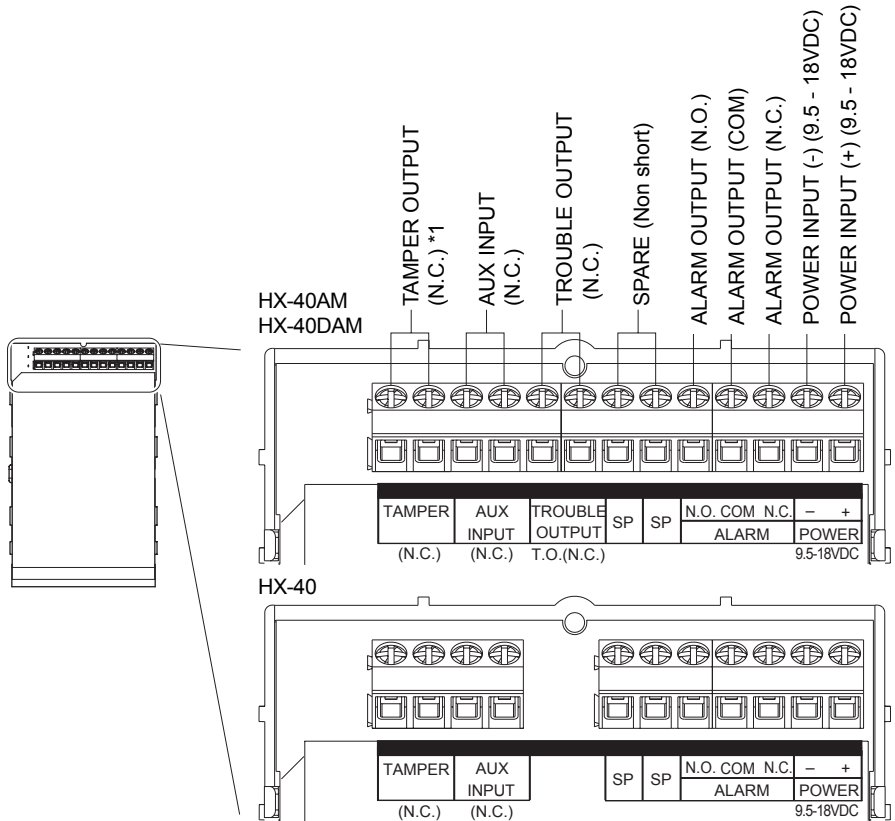

\*1: TAMPER terminals to be connected to a 24 hour supervisory loop.

## 2-5 WALL TAMPER (OPTION)

Universal magnet switch may be mounted as a wall tamper.

Installation space for universal magnet switch is provided on the back of the main unit and the bracket.

Maximum size of an applicable universal magnet switch: D 9 mm (0.35") × W 40 mm (1.57") × H 9 mm (0.35").

Universal magnet switch on the market assist is not included.

### Main unit

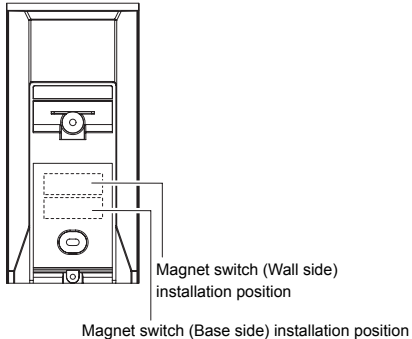

### Bracket

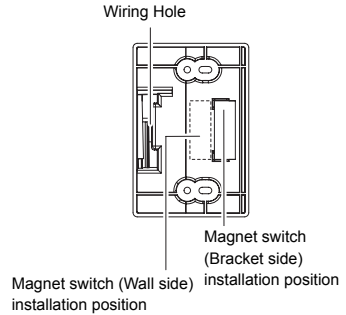

## -Installation

- 1 Install the universal magnet switch (wall side) to the wall. To determine the install position, use the "Install position template" provided on the inside cover of the product package.

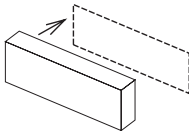

- 2 Open the wiring knockout with suitable tool e.g. screwdriver.

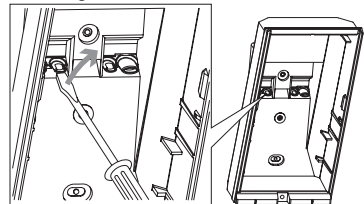

- 3 Install the other portion of the universal magnet switch to the back of the main unit or the bracket. Pull the wiring through the knockouts.

When not using the bracket

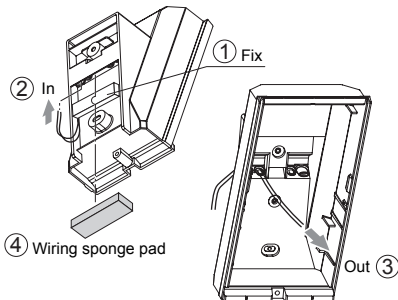

When using the bracket

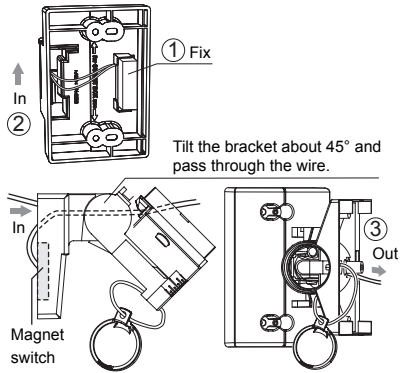

Tilt the bracket about 45° and pass through the wire.

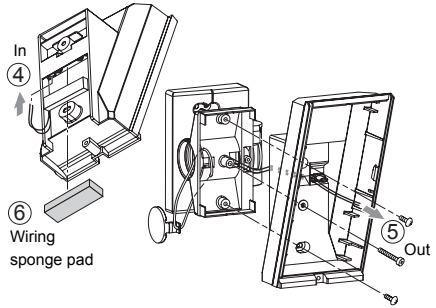

- 4 Install the bracket and the main unit to the wall surface.

- 5 Connect the universal magnet switch wiring to the tamper terminal of the main unit.

### 3 WALK TEST

- 1 Set the DIP switch 1 (LED ON/OFF) to "ON".

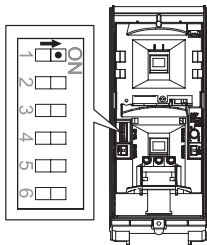

**Note>>**

The switch is set "ON" by factory default.

- 2 Check that the detector detects an object in the intended detection area. The installation has been successful if the LED lights for two seconds after a person walks into the detection area.

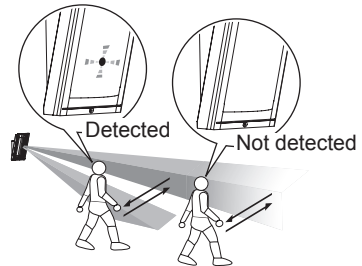

**Note>>**

For the walk test, move more than 1.0 m (3'3") away from the detector.

- 3 If the LED indication is not required at all times, set the DIP switch 1 (LED ON/OFF) to "OFF".

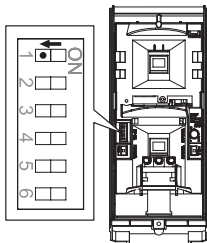

# 4

## SETTING

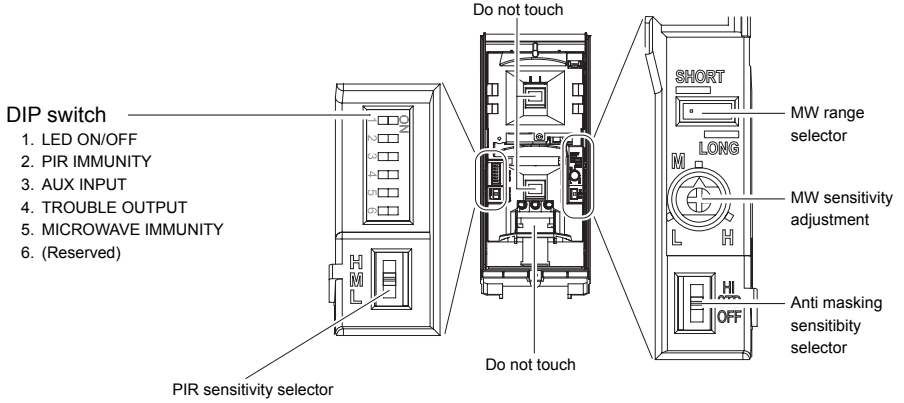

### -LED ON/OFF

DIP switch 1

HX-40  
HX-40AM  
HX-40DAM

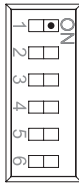

OFF ↔ ON

POSITION	FUNCTION
ON (Factory default)	The LED lights when someone is detected.
OFF	The LED does not light even if someone is detected.

### -PIR IMMUNITY

DIP switch 2

HX-40  
HX-40AM  
HX-40DAM

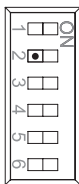

STD ↔ IMMUNITY

POSITION	FUNCTION
STD (Factory default)	PIR IMMUNITY logic is not activated.
IMMUNITY	PIR IMMUNITY logic is activated. Use this under harsh environment (e.g. small animal).

## -AUX INPUT

DIP switch 3

HX-40
HX-40AM
HX-40DAM

By connecting a satellite unit (another warning sensor), you can extend the detection area and correct false alarms. As a satellite unit, you can use any general no-voltage contact output (NC) warning sensor, including the following.

<Infrared (AIR) sensors, thermal line (PIR) sensors, universal magnet switches, etc.>

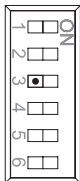

AND ↔ OR

POSITION	FUNCTION
AND (Factory default)	When both the main unit and the satellite detect someone, the alarm is output. Set to this when not connecting a satellite unit.
OR	When either the main unit or the satellite detects someone, the alarm is output.

### Notes>>

- The alarm does not output unless both the main unit and the satellite detect someone within 60 sec.
- If the OR mode is selected without a satellite unit connected, the alarm is generated continuously.

## -TROUBLE OUTPUT

DIP switch 4

HX-40
HX-40AM
HX-40DAM

Trouble output is used for anti-masking signal.

When an object is placed close to the lens surface, for a period of more than 180 sec., the IR Anti-Masking circuit is activated and generates a trouble signal.

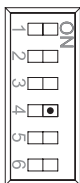

OFF ↔ ON

POSITION	FUNCTION
ON (Factory default)	Anti-masking signal is output from TROUBLE OUTPUT terminal.
OFF	Anti-masking signal is output from both TROUBLE and ALARM OUTPUT terminal.

### Note>>

Use this when not wiring a detected trouble input terminal on the control panel.

## -MICROWAVE IMMUNITY

DIP switch 5



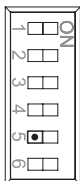







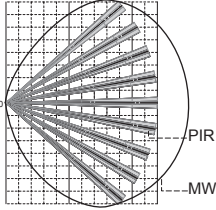

HX-40
HX-40AM
HX-40DAM

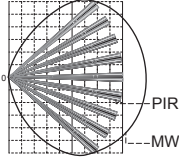

STD ↔ IMMUNITY

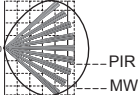
POSITION	FUNCTION
STD (Factory default)	MICRO WAVE IMMUNITY logic is not activated.
IMMUNITY	MICRO WAVE IMMUNITY logic is activated. Use this under harsh environment (e.g. vegetation sway).

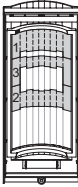
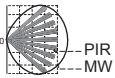
**-MW RANGE SELECTOR/MW SENSITIVITY ADJUSTMENT**

PIR AREA SETTING	DETECTION AREA (SIDE VIEW)	MW RANGE SELECTOR	MW SENSITIVITY ADJUSTMENT
<p>12.0 m (40')</p>  <p>Factory default</p>		<p>LONG</p> 	<p>MID</p> 
<p>9.0 m (29'6")</p> 		<p>SHORT</p> 	<p>HIGH</p> 
<p>5.5 m (18'1")</p> 		<p>SHORT</p> 	<p>MID</p> 
<p>4.0 m (13'1")</p> 		<p>SHORT</p> 	<p>LOW</p> 

## -PIR SENSITIVITY

PIR  
SENSITIVITY SELECTOR

HX-40  
HX-40AM  
HX-40DAM

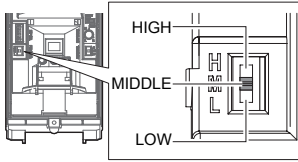

POSITION	FUNCTION
HIGH	High sensitivity
MIDDLE (Factory default)	Middle sensitivity
LOW	Low sensitivity

## -ANTI-MASKING SENSITIVITY

ANTI-MASKING  
SENSITIVITY SELECTOR

HX-40  
HX-40AM  
HX-40DAM

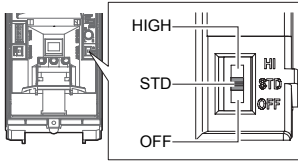

POSITION	FUNCTION
HIGH	High sensitivity
STD (Factory default)	Standard sensitivity
OFF	Disabled

### Caution>>

When closing the cover, do not leave any object within 1 meter from the unit.

## 5 AREA ADJUSTMENT

### -DETECTION LENGTH ADJUSTMENT

To limit the detection length, apply the appropriate masking seal. Note that there are three different types of seal.

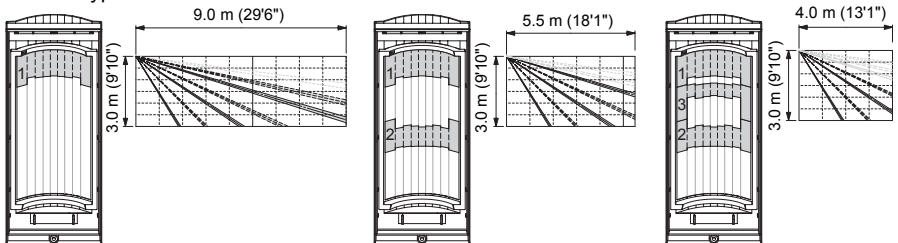

### -AREA MASKING

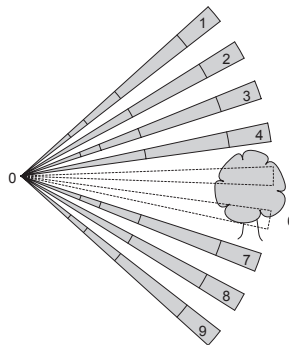
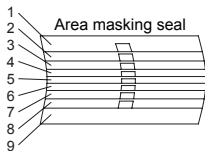

Pasting on example for  
masking No. 5 and No. 6

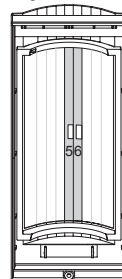



# 6

## LED INDICATION

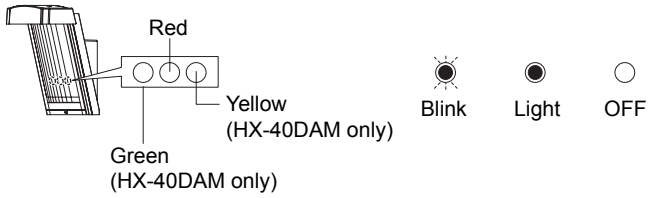

### -HX-40/40AM

DETECTOR CONDITION		LED INDICATOR (RED ONLY)
Warm-up		→ Blinks for approx. 60 sec.
Alarm		→ Lights for 2 sec.
Trouble output	Anti-Masking booting (Anti-Masking start up)	 Blinks 2 times and goes off for 5 sec. and then repeats for 180 sec.
	Masking detection	 Blinks 3 times and goes off for 3 sec. and then repeats.

### -HX-40DAM

DETECTOR CONDITION		LED INDICATOR
Warm-up		→ Blinks for approx. 60 sec.
Alarm		→ Red lights for 2 sec.
PIR detection		→ Green lights for 2 sec.
MW detection		→ Yellow lights for 2 sec.
Trouble output	Anti-Masking booting (Anti-Masking start up)	 Green and Red blink 2 times simultaneously and go off for 5 sec. This sequence is repeated for 180 sec.
	Masking detection	 Green and Red blink 3 times simultaneously and go off for 3 sec. This sequence is repeated.

## 7

## SPECIFICATIONS

## 7-1 SPECIFICATIONS

Model	HX-40	HX-40AM	HX-40DAM
Detection method	Passive infrared		Passive infrared & Microwave
PIR Coverage	12.0 m (40') 85° wide / 94 zones		
PIR distance limit	4.0 m, 5.5 m, 9.0 m (13'1", 18'1", 29'6")		
Detectable speed	0.3 m/s – 1.5 m/s (1'/s – 4'11"/s)		
Sensitivity	2.0°C (3.6°F) at 0.6 m/s		
Power input	9.5 – 18 V DC		
Current draw	35 mA (max.) at 12 V DC	40 mA (max.) at 12 V DC	50 mA (max.) at 12 V DC
Alarm period	2.0 ±1 sec.		
Warm-up period	Approx. 60 sec. (LED blinks)		
Alarm output	Form C 28 V DC 0.2 A (max.)		
Tamper output	N.C. 28 V DC, 0.1 A (max.) N.C. open when cover removed.		
Trouble output	–	N.C. 28 V DC, 0.1 A (max.)	
Aux input	N.C. 28 V DC, 0.1 A (max.)		
LED indicator	Red: Warm-up, Alarm	Red: Warm-up, Alarm, Trouble	Red: Warm-up, Alarm, Trouble Green: Warm-up, PIR detect, Trouble Yellow: Warm-up, MW detect
RF interference	No alarm 10 V/m		
Operating temperature	-20 – +60°C (-4 – +140°F)		
Environment humidity	95% max.		
Weatherproof	IP55		
Mounting	Wall		
Mounting height	2.5 – 3.0 m (8'2" – 9'10")		
Bracket adjust angle	Vertical: ±20° Horizontal: ±95°		
Weight	600 g (21.2 oz.)		700 g (24.7 oz.)
Accessories	Bracket, Hood, Area masking seal, Screw (3 × 10 mm) × 2, Screw (4 × 20 mm) × 4		

\*Specifications and designs are subject to change without prior notice.

## 7-2 DIMENSIONS

Using bracket and hood

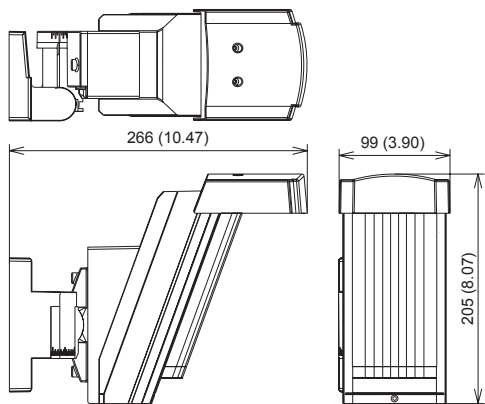

Unit: mm (inch)

Without bracket and hood

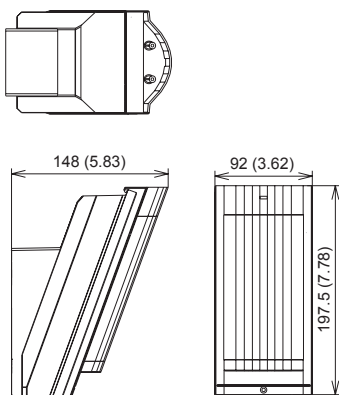

Unit: mm (inch)

## NOTE

The following statement will be provided with the equipment as required by Article 6.3 of the R&TTE Directive, 1999/5/EC.

The Optex HX series are in conformity with all essential requirements of the R&TTE Directive (1999/5/EC). This equipment has been assessed to the following standards:

EN 300 440-1: 2009

EN 50130-4: 2004 including amendment 2: 2003

EN 60950-1: 2006+A11: 2009

This product is marked with **CE07000** which signifies conformity with Class II product requirements specified in the R&TTE Directive.

The following table indicates the areas of intended use of the equipment and any known restrictions. For countries not included in this list, please consult the responsible Spectrum Management Agency.

Country of intended use	Restrictions	Country of intended use	Restrictions
Austria	9.900GHz	Luxembourg	10.525GHz
Belgium	10.525GHz	The Netherlands	10.525GHz
Denmark	10.525GHz	Spain	10.525GHz
Finland	9.900GHz	Sweden	10.525GHz
France	10.587GHz	United Kingdom	10.587GHz
Greece	10.525GHz	Other non-EU: Iceland	10.525GHz
Ireland	10.587GHz	Norway	10.525GHz
Italy	10.525GHz	Switzerland	10.525GHz

FCC ID : DC9 OPMW                      IC : 4012A-OPMW

This device complies with Part 15 of the FCC Rules. Operation is subject to the following two conditions:

(1) This device may not cause harmful interference, and (2) this device must accept any interference received, including interference that may cause undesired operation.

The HX-40 series is only a part of a complete system, therefore we cannot accept complete responsibility for any damages or other consequences resulting from an intrusion.



### **OPTEX CO., LTD. (JAPAN)**

(ISO 9001 Certified)

(ISO 14001 Certified)

5-8-12 Ogoto Otsu

Shiga 520-0101

JAPAN

TEL:+81-77-579-8670

FAX:+81-77-579-8190

URL:<http://www.optex.co.jp/e/>

### **OPTEX INCORPORATED (USA)**

TEL:+1-909-993-5770

Tech:(800)966-7839

URL:<http://www.optexamerica.com/>

### **OPTEX (EUROPE) LTD. (UK)**

TEL:+44-1628-631000

URL:<http://www.optexeurope.com/>

### **OPTEX SECURITY SAS (FRANCE)**

TEL:+33-437-55-50-50

URL:<http://www.optex-security.com/>

### **OPTEX SECURITY Sp. z o. o. (POLAND)**

TEL:+48-22-598-06-55

URL:<http://www.optex.com.pl/>

### **OPTEX KOREA CO., LTD. (KOREA)**

TEL:+82-2-719-5971

URL:<http://www.optexkorea.com/>

### **OPTEX (DONGGUAN) CO., LTD. SHENZHEN OFFICE (CHINA)**

TEL:+86-755-33302950

URL:<http://www.optexchina.com/>