

SBTL8000 Series

SBTL8000 Single lane speed gates

SBTL8011 Single lane speed gates
(w/ controller and RFID reader)

SBTL8022 Single lane speed gates
(w/ controller and fingerprint & RFID reader)

SBTL8033 Single lane speed gates
(w/ Visible Light Facial Recognition devices)

SBTL 8000 is an indoor speed gates series which featured by its modular reader panel design. The modularization of reader panel not only benefits end users for easy upgrade or switching on reader but also helps relieving middlemen's warehouse pressure and allows them to have in-time market response.

Design

In order to respond to different market needs, all barrier turnstiles based on different verification methods need to be stocked in warehouse because switching among verification methods requires additional processing on the product, thus, huge inventory and processing cost will be incurred. For overcoming the issue, modularized structure design is used in SBTL series to integrate the reader, conversion board and top cover into one modular reader panel, the installation and disassembling are only about pulling the plug and no drilling is needed. Benefited from this revolutionary design, one SBTL8000 can adopt various types of verification method which relieves inventory pressure from stocking up every types of barrier turnstile.



Performance

In order to improve the efficiency of pedestrian access management and user experience, we adopted a new type of servomotor which makes the speed gates have faster opening speed and lower noise. The test results show that the opening speed is less than 1.2 seconds with the standard barrier instead, if assembled the mid-height barrier panels, the opening speed is less than 0.8 seconds. The infrared sensors has increased to 10 pairs, which is 160% more than other similar products in order to provide more accurate logical judgment.



Quality

Casing of the product is mostly made of superior SUS304 stainless steel for its remarkably high durability. The barrier panels are made of acrylic and have better aging resistance and impact resistance. From raw material procurement to production, a strict quality control and inspection system will be applied.



Features

- modular reader panel - in-time market response
- Servomotor - faster opening speed
- 10 pairs of infrared sensors for stronger tailgate detection.
- SUS304 stainless casing
- Higher durability for longer product life cycle
- Easy switch, easy installation - RFID, fingerprint, face, etc.
- Bi-directional operation control
- LED passage indicator in both directions
- Convenient installation and maintenance
- Various optional panels
- Emergency mode allows free access when power failures or emergency



Specifications

Power requirements	AC 100 ~ 120V/200 ~ 240V, 50/60Hz
Working temperature	-28°C~ 60°C
Working humidity	20%-95% (Non-condensing)
Working environment	Indoor
Speed of throughput	Maximum 40/ minute
Lane width(mm)	660
Footprint(mm*mm)	1600 * 1040
Dimensions(mm)	L=1600, W=120, H=1200
Dimension with packing(mm)	L=1700, W=300, H=1130
Net weight(kg)	130kg
Weight with packing(kg)	150kg
Cabinet material	SUS304 Stainless Steel
Lid material	SUS304 Stainless Steel+Acrylic
Barrier material	Acrylic
Barrier movement	Swing
Emergency mode	Y

Optional panels

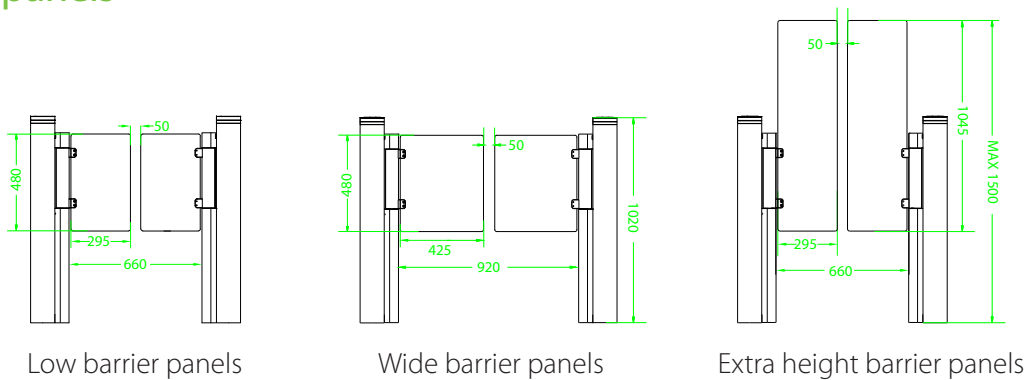

Dimensions (mm)

