

PRE-ENGINEERED SUPPRESSION SYSTEM **ARMAN***fire*[®]

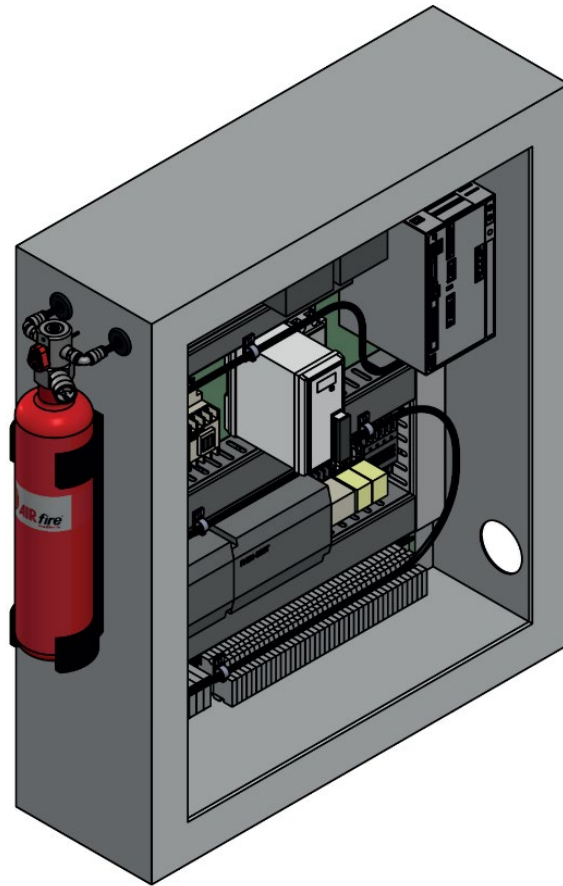

Installation and Maintenance User Manual

**Automatic fire suppression system for small enclosure
applications (LPCB Certified up to 2m³)**

FK-5-1-12

***AIR*fire[®]**
Worldwide

1	INTRODUCTION	5
1.1	GENERAL	5
1.2	HAZARD NOTICE	5
1.3	FUNCTION OF THE EXTINGUISHING SYSTEM	6
1.4	DIRECTIVES FOR USERS OF THE SYSTEM	6
1.4.1	INSTALLERS AND SERVICE PERSONNEL	6
1.4.2	FIRE SAFETY OPERATORS	7
2	SYSTEM DESIGN	9
2.1	GENERAL SYSTEM DATA	9
2.2	APPLICATION LIMITS	9
3	SYSTEM COMPONENTS	11
3.1	Extinguisher container – Cylinder (code: 03420X)	11
3.2	Cylinder valve (code: 0742A0)	12
3.3	Easydetect sensor tube (code: 125101)	13
3.4	Easydetect tube fittings	14
3.5	Cylinder brackets	14
3.6	Accessories	15
3.6.1	Signal transmitter (052004)	15
3.6.2	Pressure gauge with switch (0540XX)	15
3.7	Starterkit – Installation/ maintenance tools	16
4	INSTALLATION	17
4.1	Goods reception	17
4.2	Mounting of the cylinder	17
4.2.1	Fixing cylinder bracket	18
4.2.2	Mounting cylinder to bracket	18
4.3	Installation of the Easydetect tube	19
4.3.1	Position/ routing instructions	19
4.3.2	Drilling enclosure wall to pass Easydetect tube	22
5	SYSTEM MONITORING	23
5.1.1	Signal contact of the cylinder valve	24
5.1.2	Monitoring using signal transmitter	25
5.1.3	Connection of pressure gauge with contacts	25
6	COMMISSIONING	27
6.1	Pressurising the Easydetect tube	27
6.2	Opening cylinder valve	28
6.3	Installation Quick Check	29
7	OPERATIONS	30
7.1	Automatic fire detection	30
8	SERVICING/ MAINTENANCE	31

8.1	Reinstatement work after system discharge	31
8.1.1	Replacement of single use components	31
8.1.2	Replenishing discharged extinguishing agent	31
8.2	Servicing after an interval	31
8.2.1	Service intervals	31
8.2.2	Maintenance schedule	32
8.2.3	Yearly check – System functionality check	32
8.2.4	Biannual check – Checking operational state of components	32
8.2.5	10year check – General maintenance	33
8.3	Service and maintenance records	33
9	APPROVAL AND MARKING OF SYSTEM	34
10	PRODUCT LIABILITY	34
11	ANNEX 1 – SYSTEM LAYOUT	36
12	ANNEX 2 – FK-5-1-12 FEATURES	37
13	ANNEX 3 – TRAINING PROGRAMME	42
14	ANNEX 4 – SERVICE AND MAINTENANCE CHECK LIST	43
15	ANNEX 5 – Caution label for protected enclosure	44
16	List of figures	45

Version	Amendment date	Amendment	Staff
1.0	21/04/20	Manual creation	A.Esteruelas
1.1	29/04/20	Vent area and temperature range updated	A.Esteruelas
1.2	07/09/22	Part 3.6.2 Updated	A.Esteruelas

IMPORTANT

The information contained in this manual is property of AIRfire Worldwide, who reserve the right to carry out changes without prior notice. No reproduction, modification, total or partial translation is allowed for any purpose than internal use. Every effort has been made to ensure accuracy of information contained herein, however, AIRfire disclaims any liability for the use that may be made of this information. Anyone using the data contained in this manual does so under their own responsibility and assumes whatever consequence they may encounter.

Any questions concerning the information presented in this manual should be addressed to:



C/ Mata 21, Local
08004 – Barcelona – Spain
Tel: (+34) 933 249 094
info@airfire.eu
www.airfire.eu

Thank you for your trust in AIRfire, your confidence increases our desire to follow ahead.

NOTE:

Unless otherwise stated, images/ diagrams are for illustrative purposes only. Colours and dimensions may not represent the true product. Always verify Technical Datasheets for as-built characteristics.

1 INTRODUCTION

1.1 GENERAL



The terms **DANGER, WARNING, ATTENTION** denote that non-compliance with the warnings can cause severe injuries and even fatalities, or that there is the risk of substantial material damage. All other notices shall also be observed to prevent faults and resulting personal injuries and material damage.

Do not expose yourself or others to hazards. Carefully read the following safety instructions before installing, operating or servicing the system equipment, to prevent accidents, personal injuries and material damage. The fittings and the product itself shall only be used for the intended purposes.

Limits and values listed in these operating instructions shall be observed, particularly operating pressures, ambient temperatures and dimensions of the system installation too. The company AIRfire will accept no liability for damages resulting from improper use or non-compliance with the instructions in this user manual.

1.2 HAZARD NOTICE

All work shall be performed by qualified personnel trained according to the operating instructions throughout the service life of the system. Qualified personnel mean all persons officially trained by AIRfire in the planning, installation, commissioning, operation and maintenance of the gas suppression systems. Furthermore, the personnel shall comply with:

- Regional, national and internal regulations and safety standards.
- Use of appropriate safety equipment and work apparel.

These operating instructions are intended for all persons installing, operating and servicing the products and fittings listed below. It is assumed that all involved in these tasks are aware of the general rules and safety guidelines for handling gases and pressurized units. It is also assumed that the personnel are acquainted with handling electrical components.

In case of difficulties with operating the pressure units that cannot be resolved by consulting these instructions further information must be requested from the manufacturer, AIRfire.

Manipulate all vessels with extreme care, never assuming they are empty. Always as if pressurised.

The manufacturer reserves the right to implement technical changes, improvements, and amendments. Always consult the newest version of this user manual.



The extinguishing system described in this user manual may only be used for the protection of enclosures meeting the designated system limits, otherwise the protective function cannot be guaranteed.

Any modification of components and materials is prohibited, only parts which are listed in this manual and properly functioning must be used. Unsuitable tools and working practices entail risks for personnel injuries and malfunctions.

Ignoring these instructions can cause severe personal injuries and material damage.

1.3 FUNCTION OF THE EXTINGUISHING SYSTEM

The ARMANfire System is designed as a fixed fire suppression system, where the extinguishing agent is stored in a pressurised vessel with nitrogen at an operating pressure of 18 bar. The nitrogen acts as the propulsion gas expelling the extinguishing agent, as well as compensation for natural micro leakages over time. The valve of the vessel is maintained shut by external pressure coming from the Easydetect sensor tube.

The Easydetect sensor tube is a linear thermal detector mounted inside a defined enclosure (LPCB certified volumes of up to 2m³) covering all risks within it to ensure rapid fire detection. If a fire occurs in the enclosure, the sensor tube that is pressurised with nitrogen, (18 bar internal pressure, as in the pressurised vessel) bursts due to the continuous heat rise. After it occurs, the extinguishing agent is discharged from the same hole that the fire has produced in the Easydetect sensor tube.



Enclosures may only be operated with a properly installed and fully functional extinguishing system so to avoid fire propagation to adjacent enclosures in case of a fire.

Notes to take into consideration regarding ARMANfire systems:

- Regular visual inspections of the vessel pressures on the pressure gauges ensure the system function and operation outside the service intervals.
- The extinguishing agent is clean agent in gaseous form when discharged, FK-5-1-12, it is colourless, odourless and electrically non-conductive. It is non-toxic and leave no residue upon discharge.
- The main extinguishing mechanisms of clean agent is by removing enough heat from the fire and interrupting the combustion chain reaction.

1.4 DIRECTIVES FOR USERS OF THE SYSTEM

1.4.1 INSTALLERS AND SERVICE PERSONNEL

There are two different useful ways to use this manual. First, following the index accurately step by step (mainly when it is the first system to be installed and the personnel has no previous experience) and secondly, as a reference book. In both cases, it is necessary the use of the drawings provided with the system for accurate, project specific installation.

Intention of this manual is to give specific instructions for installation, maintenance, and testing requirements for AIRfire systems and components. In any case is intended to accomplish any requirements of the applicable and mandatory standards of design and installation of systems.



AIRfire systems may only be installed by specialist companies with the required expertise, qualified personnel trained by the manufacturer AIRfire directly.

The installer of the extinguishing system is responsible for the layout, dimensioning of the fire extinguishing system, as well as determining the suitability of the fire protection application, the correct installation and labelling of the approved installed system.

- AIRfire recommends always the adoption of safe working practices in accordance with current health legislation and safety procedures. It is recommended that personnel in charge of installation and maintenance of the fire extinguishing system should be properly trained in its safe use and should read the whole of this manual before initiating any of the operations mentioned above.

- During installation and maintenance operations personnel should be protected by wearing protective clothing and shoes and when necessary helmet and gloves. Safety glasses or facemask should be worn whenever holes are drilled for pipe supports or cylinder bank brackets. Such protection is also needed when dealing with particle emission.
- All the equipment shall be installed in accordance with the design parameters. Systems are made up of units tested within limitations. The system designer shall be consulted whenever changes are planned for the system or area of protection.
- Any deviations exceeding the approved system parameters will automatically invalidate the system approval.



The manufacturer and/or the installer of the fire extinguishing system shall deliver technical documentation and system-specific operating instructions at the time of commissioning the system to the End User.

In addition, the operating instructions to the individual components complementing the information in this documentation must be observed.

Do not hesitate to contact AIRfire in case of overlapping, missing information or doubts.

1.4.2 FIRE SAFETY OPERATORS



The system components shall never be damaged, disassembled or readjusted during operation of cleaning/ maintenance work. A qualified installation technician from the installing company shall be contacted in case of doubt.

This manual is written for those who install, operate and maintain ARMANfire fire extinguishing systems manufactured by **AIRfire Worldwide**. It contains system installation, operation and maintenance instructions

ARMANfire fire suppression systems designed and manufactured by AIRfire are considered as heavy-duty equipment, reliable and easy to mount, with simple test routines to check their operating condition as described in this manual. However, **AIRfire Worldwide** wishes to clarify the following points:

- All personnel who are assigned to the equipment shall be properly trained in its use, inspection, tests and maintenance.
- AIRfire recommends always the adoption of safe working practice in accordance with current health legislation and safety procedure. It is recommended that personnel in charge of installation and maintenance of the fire extinguishing system should be properly trained in its safe use and should read the whole of this manual before initiating any of the operations mentioned above.
- All the equipment is installed in accordance with the project drawings. Systems are made up of units tested within limitations. The system designer shall be consulted whenever changes are required to the system or area of protection.
- An authorized installer or system designer shall be consulted after the system has discharged.

Check the system for its functionality in regular intervals and before starting daily work. This includes inspection of the vessel pressure on the pressure gauge and checking the red ball valve position on the cylinder valve.

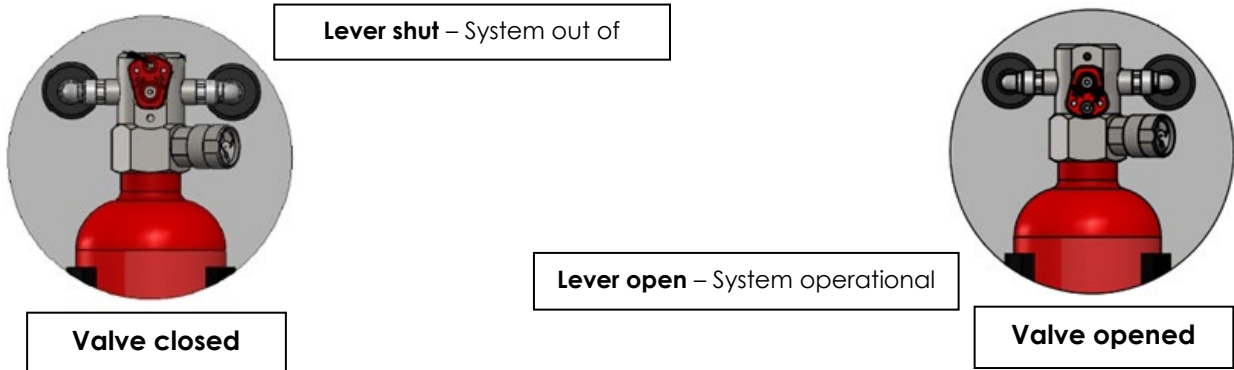

Figure 1 - Ball valve position

Never sever the sensor tube as this would trigger the extinguishing process.

The ball valve of the extinguishing system must never be shut by non-authorized staff as this would prevent any extinguishing action.

2 SYSTEM DESIGN

2.1 GENERAL SYSTEM DATA

Extinguishing agent used (ISO name)	FK-5-1-12
Nomenclature	1,1,1,2,2,4,5,5,5-Nonafluoro-4-(Trifluorometil)-3-Pentamona
Chemical formula	CF ₃ CF ₂ C(=O)CF(CF ₃) ₂
System pressure (at 20 °C)	18 bar
Operating temperature range	-20 °C to +60 °C
Propelling gas	Nitrogen (N ₂)

Toxicological information:

Property	Value % by volume FK-5-1-12
No Observed Adverse Effect Level (NOAEL)	10,0
Lowest Observed Adverse Effect Level (LOAEL)	>10,0

2.2 APPLICATION LIMITS

Direct low-pressure application fixed fire suppression system, ARMANfire, is used for the protection of small unoccupied defined enclosures such as electrical switchgear cabinets, server racking and similar installations from small local flaming fire sources. The system uses a single method of detection and delivery of the extinguishing agent to the fire ignition point., called *Easydetect* tubing, a heat sensitive pneumatic detection tubing.

The ARMANfire system is intended solely to provide improved local fire protection that may occur within enclosures of a defined volume and prevent possible fire propagation to adjacent enclosures. It is not intended for use as whole room or building fire protection system. To guarantee complete fire protection always, applicable fire safety codes shall be followed.

Limitations in the use of FK-5-1-12 extinguishing agent:

Agents may be used for extinguishing fires of all classes within limits. Unless relevant testing has been carried out to satisfaction, FK-5-1-12 shall not be used on fires involving:

- Chemicals containing their own supply of oxygen, such as cellulose nitrate;
- Mixtures containing oxidizing materials, such as sodium chlorate or sodium nitrate;
- Chemicals capable of undergoing autothermal decomposition, such as organic peroxides;
- Reactive metals (such as sodium, potassium, magnesium, titanium and zirconium), reactive hydrides, or metal amides, some of which may react violently with some gaseous extinguishants;
- Environments where significant surface areas exist at temperatures greater than the breakdown temperature of the extinguishing agent and are heated by means other than the fire.

Limitations for the protected enclosure:

Maximum protected volume	Up to 2 m³
Maximum free vent area	Up to 0.025 m² 0.0125 m² at the top level of the cabinet + 0.0125 m² at the bottom level of the cabinet
Design concentration, LPS 1666 Issue: 1.0	FK-5-1-12: 6.7%

There are system variants (sizes) available, characterised mainly by the size of the enclosure to be protected and the quantity of extinguishing agent.

The variants should be selected according to the table below:

System code for FK-5-1-12	Quantity of agent	Maximum protected volume	Maximum free vent area
ARFFK501TB	1 Kg	Up to 1 m³	Up to 0.025 m²
ARFFK502TB	2 Kg	Up to 2 m³	0.0125 m² at the top level of the cabinet + 0.0125 m² at the bottom level of the cabinet
ARFFK503TB	3 Kg		
ARFFK504TB	4 Kg		
ARFFK506TB	6 Kg		

Apart of the volume, it is important to consider the free vent areas (openings with no forced ventilation) of the enclosure.



In case the protected enclosure has a forced ventilation system, the ARMANfire fixed fire suppression system shall have a signal transmitter (052004) installed. This signal transmitter shall turn off the forced ventilation when the system is activated.

In case of installation requirements where one or several values exceed the limits of the system specified above, consult AIRfire. It may be possible to achieve the protection level by installing additional systems.



The dimensions and numbers listed above are the system limits and shall be followed.

They are confirmed having successfully completed the test procedures as specified in LPCB, LPS 1666 Issue: 1.0. Within these limits a comprehensive and safe extinguishing effect can be expected. In case individual or several limits are exceeded, protection cannot be guaranteed.

3 SYSTEM COMPONENTS

The ARMANfire fixed fire suppression systems consist of various components that have been examined and tested individually to guarantee reliability and suitability for use. After which they have been tested assembled as systems according to requirements and test procedures set forth by LPCB LPS 1666 Issue: 1.0.

3.1 Extinguisher container – Cylinder (code: 03420X)

There are some cylinder sizes available, selected according the enclosure volume to be protected.



Figure 2 - Cylinder layout

Cylinder type	Part number	Cyl. volume/ Max. extinguishing agent	Diameter [J] (mm) +/- 1%	Height [L] (mm)	Colour
1	034201	1.3 litre/ 1 kg of agent	80	314 (+/-2)	RAL 3000 (red)
2	034202	3,8 litres/ 2 or 3 kg of agent	140	305 (+/-2)	
3	034203	7.5 litres/ 4 or 6 kg of agent	160	440 (+/-2)	

Cylinder thread	M30x1,5
Working pressure	24 bar
Test pressure	34.3 bar
Burst pressure	64.8 bar
Working temperature	-20 °C to +60 °C
Dip tube inner diameter	12 mm
Dip tube thread connection	M16x1.5



Dip tubes must be selected according to the cylinder used, otherwise there is risk that the entire extinguishing agent is not expelled during system discharge.

Compensation volume

This is the volume of the propellant gas (Nitrogen) inside the cylinder above the extinguishing agents.

The compensation volume has the following functions:

- Provide energy required to expel the extinguishing agent at the corresponding extinguishing pressure.
- Compensation of micro leakages (e.g. natural diffusion through plastic and seals due to permeability).

In case of excessive leakage, the compensation volume will shrink, and the extinguishing effect will be reduced due to insufficient pressure. To prevent this, regular servicing is essential. In addition, AIRfire recommends installing pressure gauges with electric contact to monitor the pressure levels and to sound an alert signal in case of a drop of pressure below a minimum.

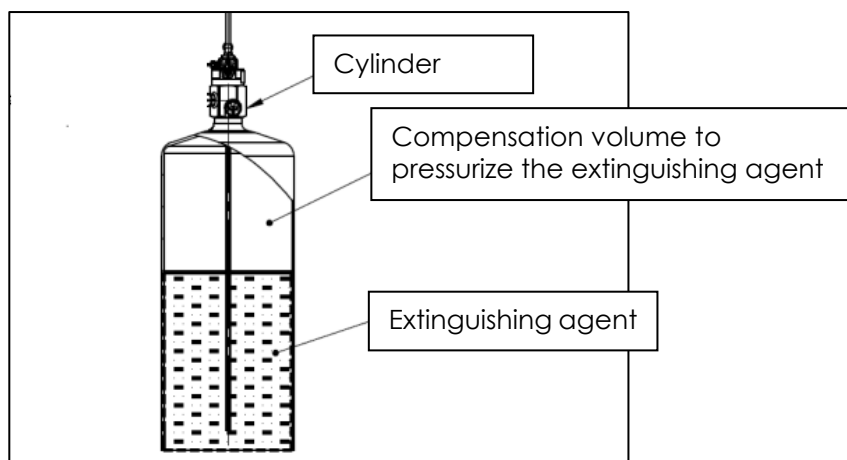

Figure 3 - Compensation volume

3.2 Cylinder valve (code: 0742A0)

This pneumatically actuated cylinder valve is the main component of the system due to its connection between the Easydetect sensor tube and the cylinder. The valve will open upon a drop-in pressure inside the sensor tube (burst due to heat rise/ flame) and opens allowing the discharge of the extinguishing agent.

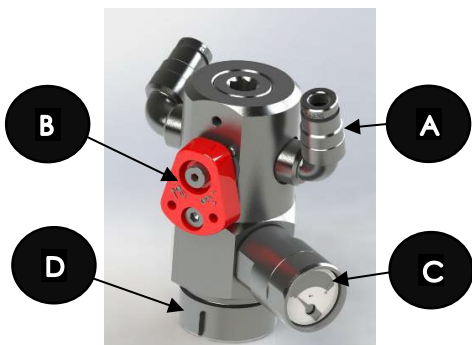

Figure 4 - Cylinder valve

Pos.	Description	Value
A	Sensor tube connection	Ø6 mm
B	Ball valve lever	Open – Close (0° - 180°)
C	Pressure gauge	Connection thread M10x1
D	Cylinder connection thread	M30x1.5

The valve includes a dry contact that provide electrical signal when the ball valve lever is closed. That is why they must be connected to the fire alarm panel so to provide an alarm status when the system is closed for maintenance procedures for example.



If during servicing the ball valve lever (B) is closed, it must be ensured that the valve will be reopened later; otherwise the suppression system is out of service and not available in case of a fire. By employing the valve lever position monitoring dry contact this risk can be avoided. If the valve is closed a signal is emitted.

3.3 Easydetect sensor tube (code: 125101)

o

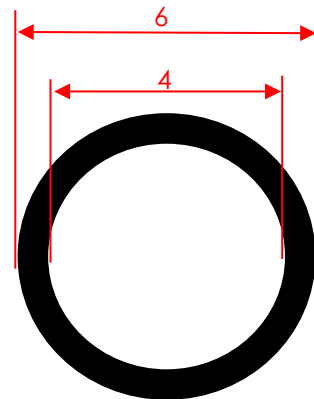

Figure 5 - Easydetect sensor tube

Polymeric tubing with thermal detection capabilities. Easydetect sensor tube is made of high-tech polymers especially developed for the use as a thermal linear detector in automatic fire suppression systems. Due to thermal material properties and the inner over-pressure the sensor tube bursts when touched by a flame or subjected to excessive heat increase.

Technical Specifications:

Part number	125101
Dimensions	Ø6x1 mm (inner Ø – 4 mm)
Recommended bending radius	150 mm (min. 100 mm)
Operating pressure	18 bar, max. 28 bar at Tmax
Operating temperature	-20 °C to +60 °C
Bursting temperature	150 °C
Permeability	10-4 mbar l / sec (Helium)

Marking:

===== - ARMANfire - 125101 - WW/YYYY - XX – Detecting Tube – Tubo rivelatore –
Tubo de detección - Capteur de Feu – www.airfire.eu - =====



The maximum Easydetect sensor tube length from the container outlet to the end of any single detection tube run shall not exceed 10 m.

Only using AIRfire Easydetect tube and installing as indicated in this document, rapid and efficient fire detection without the risk of false alarms is guaranteed.

3.4 Easydetect tube fittings

To facilitate different system configurations and set ups, the following Easydetect tube fittings are available:

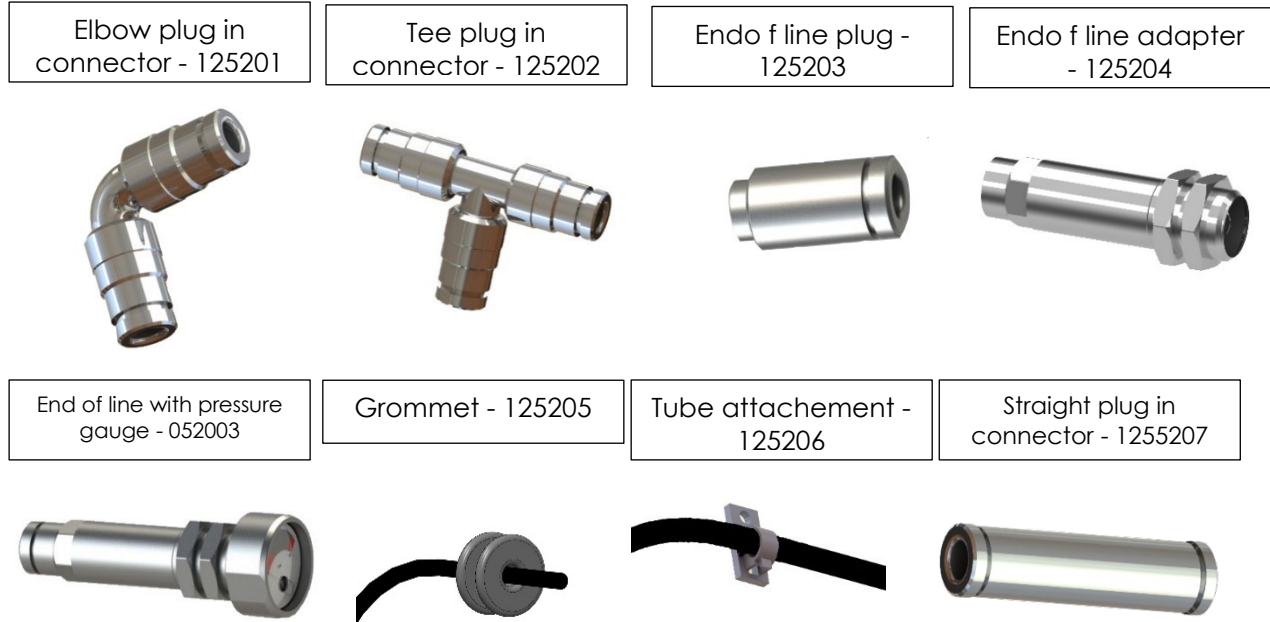

Figure 6 - Easydetect tube fittings

3.5 Cylinder brackets

Bracket is used to fix the cylinders to the wall or to the ground. There are 3 models of brackets depending on the cylinder size. For more details, see its data sheet TDS082XXX

Cylinder size	Bracket code
1.3 Litres	082301
3.8 Litres	0825A0
7.5 Litres	0825A1

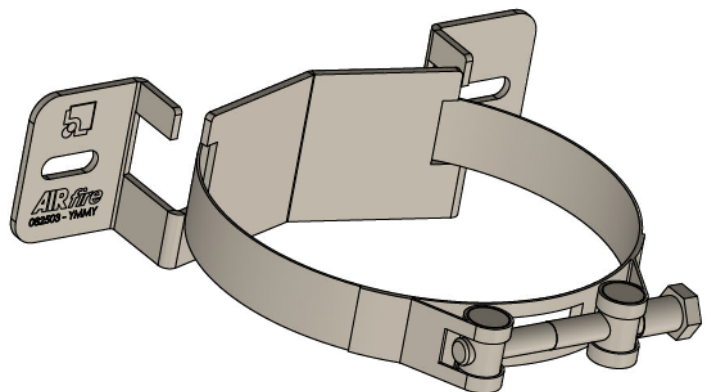

Figure 7 - ARMANfire bracket

3.6 Accessories

3.6.1 Signal transmitter (052004)

Signal transmitter is used to send an electrical signal when the pressure of the Easydetect tube decreases. With this signal, allows real time monitoring of the system and know when it is discharged or there is leakage in the Easydetect tube line. This device is connected to the Easydetect tube through an end of line adapter (125204).



Figure 8 – Signal transmitter

3.6.2 Pressure gauge with switch (0540XX)

Allows visual check of the pressure and includes a switch to send an electrical signal in case of leak. This device can be mounted to the cylinder valve to monitor the pressure inside the cylinder or at the End of line adapter (125204) to monitor the pressure in the Easydetect tube.

Designation	Pressure gauge N.O.	Pressure gauge N.C.
Code	054006	054016
Switching mode without pressure	Open	Close

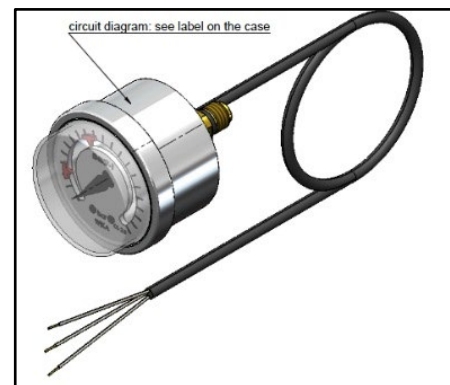

Figure 9 - Pressure gauge with contact

3.7 Starterkit – Installation/ maintenance tools



Figure 10 - Starterkit

1. **Special tube scissors** – To cut the Easydetect tube correctly according specifications.
2. **Deburring tool** – To deburr the Easydetect tube for an easy quick coupling with fittings.
3. **Multi-tool** – For the installation of the system
4. **Easyfill** – For the pressurization of the Easydetect tube. It contains preferably nitrogen (N₂).
5. **Filling connector G1/8"** – For the refilling of the extinguishing cylinders through Easydetect tube outlet of the valve.
6. **Filling connector M10** – For the pressurization of the Easydetect tube with the Easyfill
7. **Filling adapter** – Adapter to fill the Easyfill
8. **Laser pointer** – For the adjustment and alignment of the nozzles (Only for ARMANfire Chef kitchen systems)



The Easyfill is used to provide pressurized gas (up to 200 bar) during installation and servicing, since the Easydetect sensor tube must be filled before opening the cylinder valve to avoid accidental discharge. In addition, the top-up pressurization of the extinguishing agent within the cylinder the can be done with the Easyfill if no other source is available.

4 INSTALLATION

4.1 Goods reception

1. Check all the material is according to delivery documentation. If you have any doubts do not hesitate to contact with AIRfire.
2. Carefully unpack the cylinder storing it in a safe place without removing the cap until necessary. Carefully place the components of the system for easy manipulation.



WARNING: The cylinder is under pressure and must always be manipulated with great care. The ball valve must always remain closed and secured during manipulation and storage.

4.2 Mounting of the cylinder

The pressurized cylinder must be mounted and fastened securely in a vertical and upright position for operation.

Specific ARMANfire brackets supplied by AIRfire or its distributors shall be used.

Horizontal mounting is not permissible as in this position the dip tube will only collect and expel a fraction of the extinguishing agent not guaranteeing extinguishing of the fire.

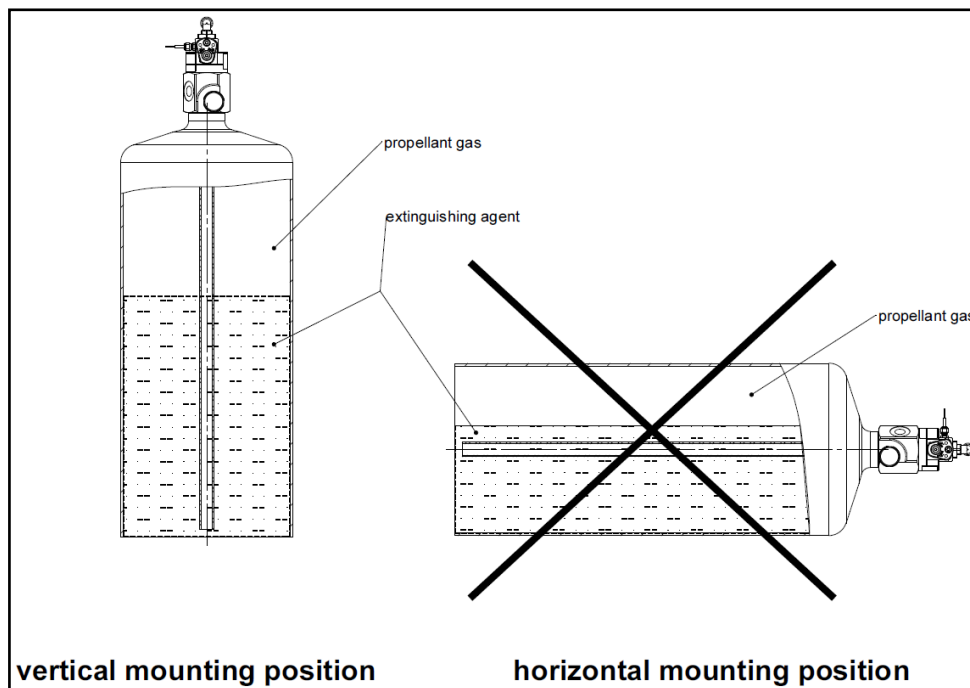

Figure 11 - Mounting position

4.2.1 Fixing cylinder bracket

The cylinder bracket must be fixed to a firm wall, structure or support, capable to sustain complete cylinder assembly weight.

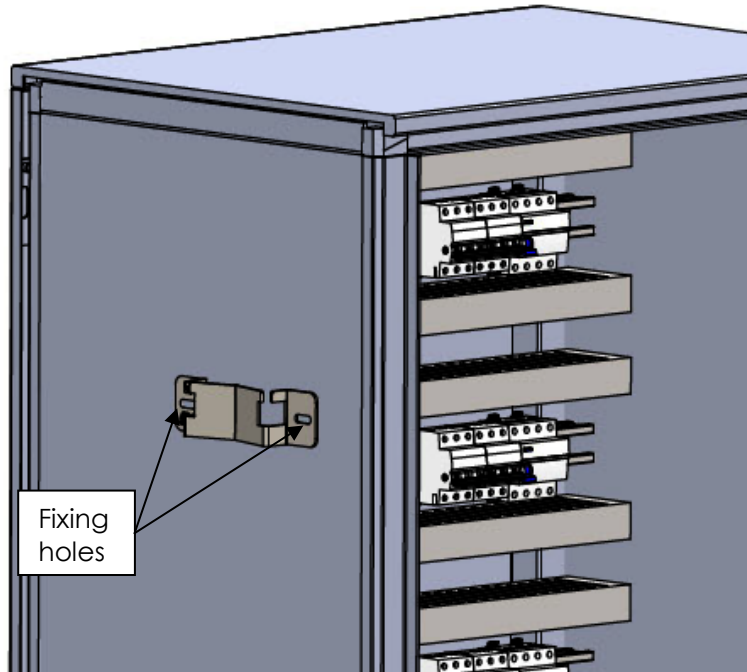

Figure 12 - Cylinder in bracket

Note: The screws must be suitable for the material they will be fixed to and installed according specifications (not supplied by AIRfire).

4.2.2 Mounting cylinder to bracket

Carefully, locate cylinder into bracket and fasten clamp.

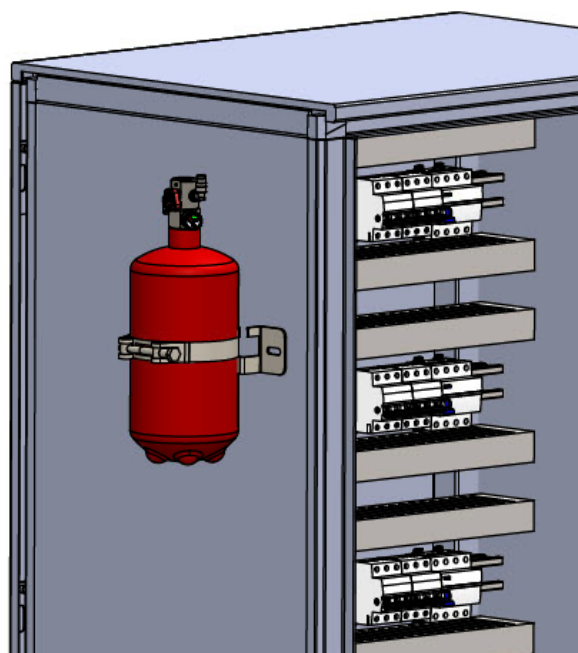

Figure 13 - Cylinder in bracket

In case you couldn't fix the cylinder bracket to a firm wall, structure or support, AIRfire has special floor bracket available. This bracket can be fixed to the floor.

Cylinder size	Bracket code
3.8 Litres	0826A0
7.5 Litres	0826A1

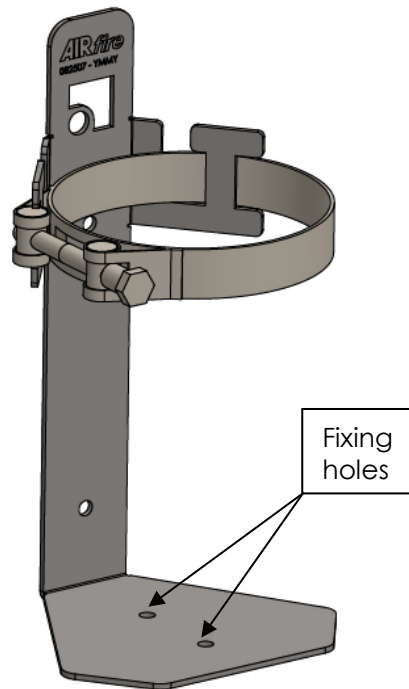

Figure 14 – Cylinder floor bracket

4.3 Installation of the Easydetect tube

4.3.1 Position/ routing instructions

The Easydetect tube must be installed as close as possible to the fire hazards within the enclosure, so that it may react rapidly upon flame detection. However, ensure that the tube is not mounted too close to heat sources, this would result in accelerated degradation of the tube material provoking unintended system activation.

Limits for sensor tube installation:

Maximum tube length	10 m per valve outlet
Smallest permissible bending radius	100 mm
Maximum distance from a potential secondary fire source within the cabinet	500 mm
Maximum activation height (MAH) above protected risk	150 mm
Maximum tube attachment spacing	250 mm



The end of the Easydetect tube not connected to the valve must be terminated with an end-of-line adapter or plug. Use only AIRfire tube fittings, which are tested and approved for the intended application.

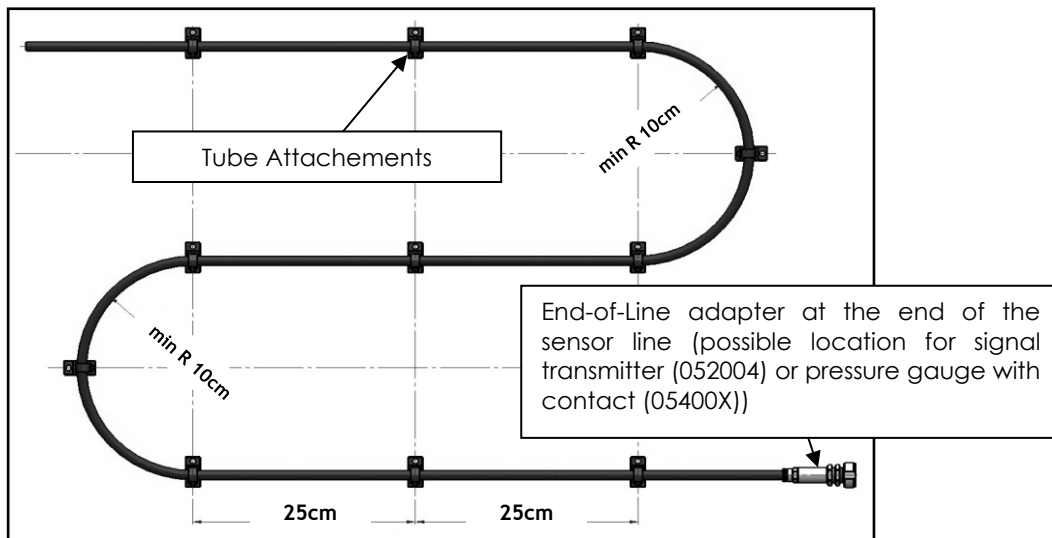

Figure 15 - Easydetect tube



The maximum specified Easydetect tube length may not be exceeded. Excessive use of fittings increases leakage risk.

Warnings:

- The reaction time increases with the distance between the fire source and the sensor tube.
- If the sensor tube is covered by other components the reaction time is increased or it will react only when the fire has spread much further.
- Observe the mounting instructions to prevent uncontrolled movement of the tube ends during a discharge.
- Do not lay the tube over sharp edges (use bulkhead fittings or rubber bushings), avoid buckling and kinks.
- To ensure an improved burst behaviour the sensor tube should not be mounted flush on surfaces, use suitable mounting fixtures.
- The bend radius must not be less than 100 mm, otherwise the tube may kink or buckle. Tube attachments (125206)

Use elements to fix the sensor tube, meeting the following requirements:

- The sensor tube must not be covered up,
- The mounting elements must be suitable and approved for the use in the enclosure to be protected (aging, stability...),
- The sensor tube can be fixed with cable ties if no other attachment is available.

Fixing the Easydetect tube with the tube attachments supplied guarantees proper support, the adhesive base allows easy positioning and modification. The hole allows definitive fixture with a screw.

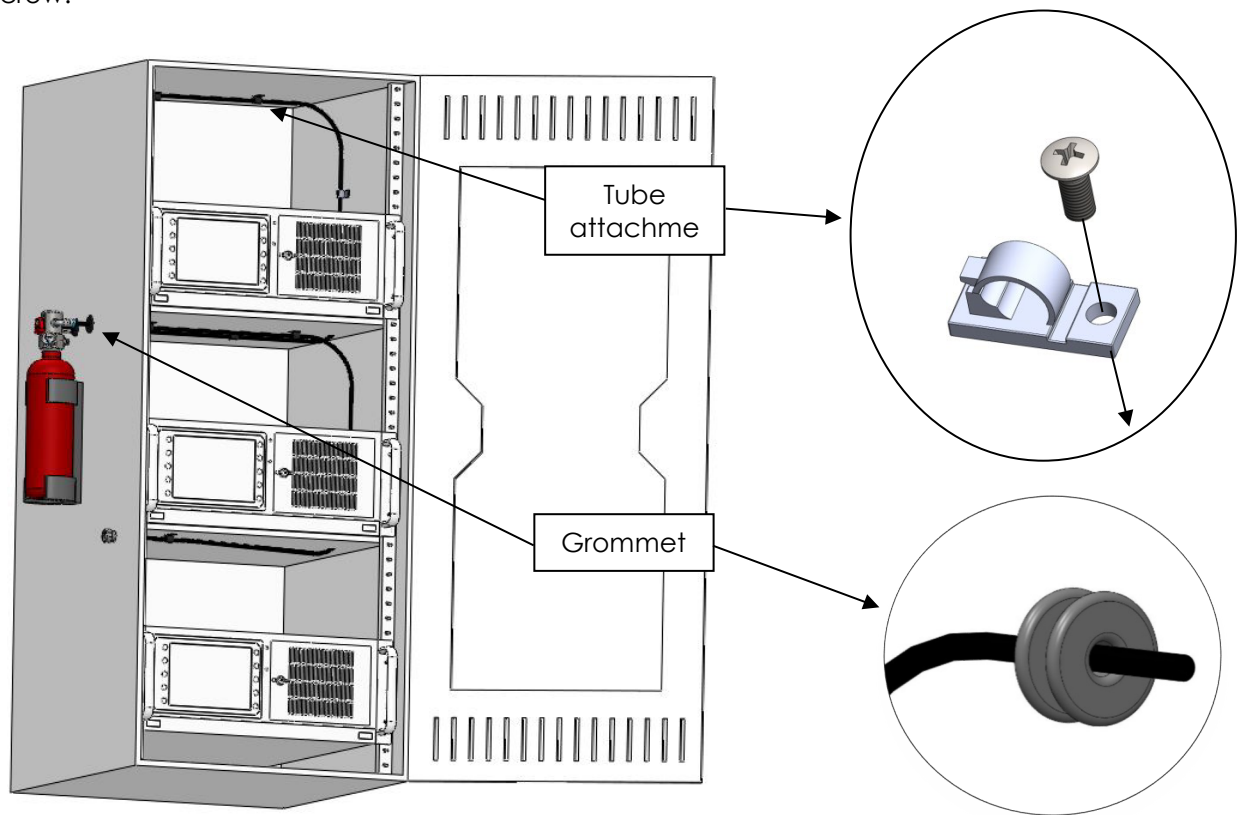

Figure 16 - Easydetect tube routing example

4.3.2 Drilling enclosure wall to pass Easydetect tube

- Make a mark where the Easydetect tube will pass inside the protected enclosure according to the valve outlet position.
- Carefully remove the cylinder of the bracket.
- With an 8 mm drill bit, carefully perforate the wall.
- Insert the grommet (125205) in the hole done.
- Mount the cylinder again to the bracket.

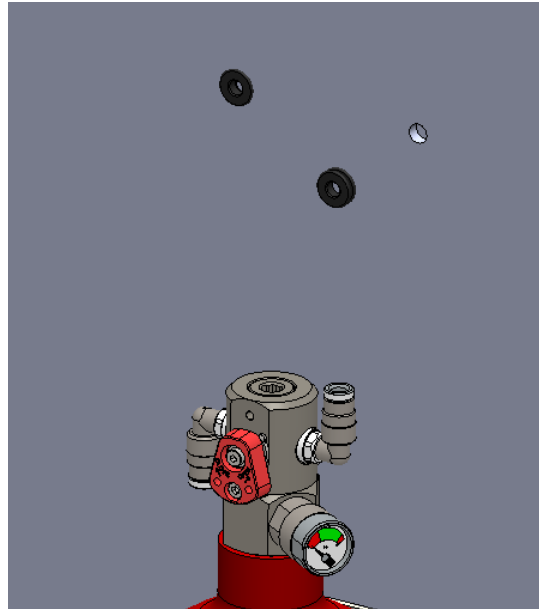

Figure 17 - Grommet positioning

- Install the Easydetect tube respecting the lengths and radius commented in section 4.3.1. of this document.
 - Using the scissors and deburring tool (items 1 and 2 of the Starterkit, section 3.7. of this document), to cut and deburr the Easydetect tube before fitting in the Easydetect couplings.
1. Insert the Easydetec tube into the deburring tool.



Figure 18 - Deburring tool 1

2. While carefully inserting the tube, rotate the deburring tool until reaching the stop position.

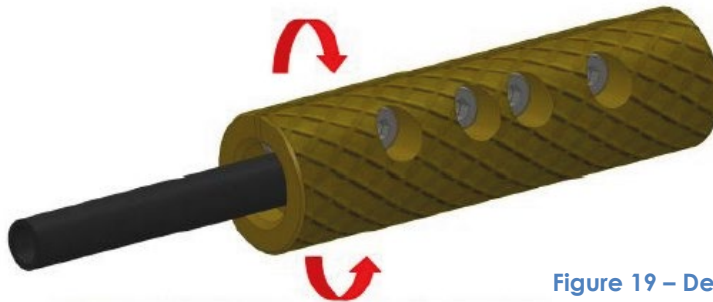

Figure 19 – Deburring tool 2

3. The result is a chamfer of 20° which avoid damages to the quick coupling connector's o-rings.



Figure 20 – Deburring tool 3

5 SYSTEM MONITORING

To ensure optimum system operation, AIRfire provides various options for electric system monitoring easily integrated with any control system generating a signal allowing specific operations to be carried out.

ARMANfire systems' monitoring components:

- Position of the lever of the cylinder valve (open or close) - Cylinder valve (0742A0)
- Pressure inside the Easydetect tube using Signal transmitter (052004)
- Pressure inside the vessel using Pressure gauge with contact (05400X)

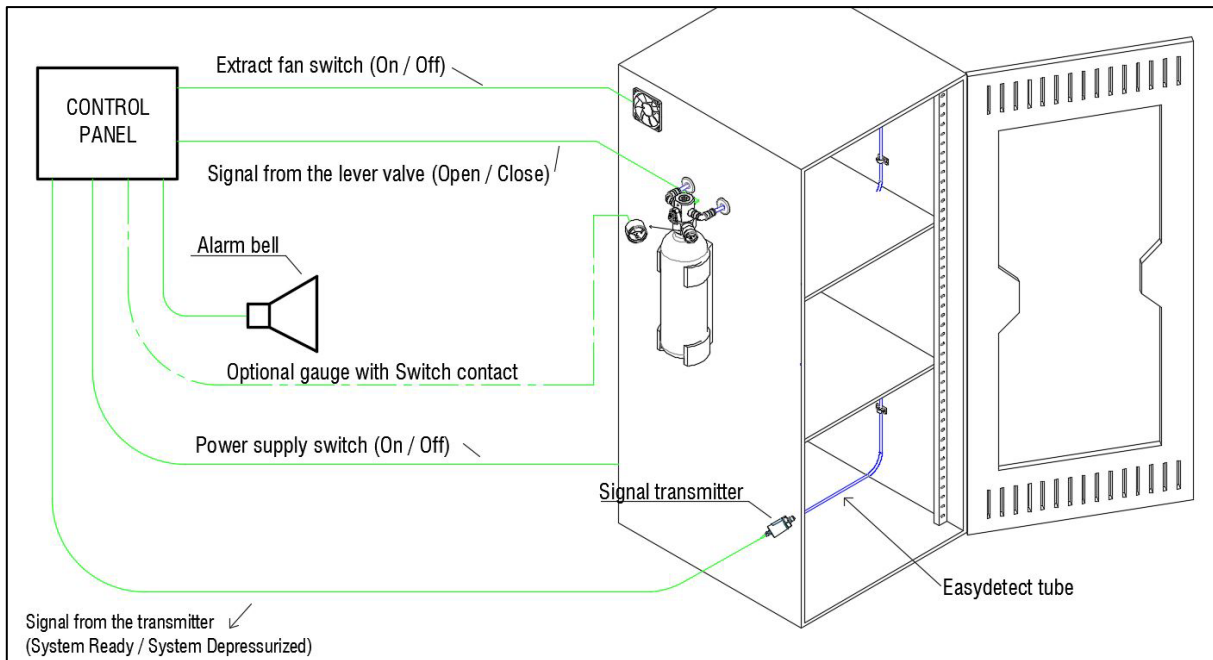

Figure 21 - System monitoring scheme

The monitoring components correctly connected to the fire control panel that is in turn connected to the protected enclosure, are capable of:

- Isolating any power supply associated with the protected enclosure upon discharge.
- Connecting to a sounder or other alarm activation system, notifies system operation.
 - There may be cases, where operation notification is not necessary upon evaluation of the application, such as remote and/ or isolated enclosures.
- Displaying, monitoring and providing a low-pressure alarm.

It shall not be possible for the end user to isolate any alarm connections to the ARMANfire system without also isolating the power supply to the enclosure and placing the system into an alarm status.



If the end user does not require operational shut down of the enclosure during ARMANfire system maintenance this shall be clearly stated in the equipment documentation and training.

Using enclosure equipment while the suppression system is inactive or out of service for other reasons is strongly not recommended.

5.1.1 Signal contact of the cylinder valve

Cable	Contact status
UL2464 – 2 x AWG28 cable length: approx. 500 mm	Ball valve open → Contact closed Ball valve closed → Contact open

ELECTRICAL DATA			
Contact rating	Max. W / VA 10	Switching voltage	24 Volt (Max. VDC 180 / VAC 130)
Switching current	Max. A 0,7		

5.1.2 Monitoring using signal transmitter

The signal transmitter is used for monitoring the actuation and must therefore be installed in line with the sensor tube, using an End-of-line adapter (125204).

Cable type: UL 2464 – 2 x AWG28 - Length: approx. 500 mm

COLOURS	
BLACK	COM
RED	NO - Detecting tube pressurized--> contact closed

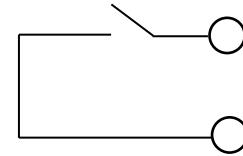

Figure 22 – Status of pressure switch without pressure

ELECTRICAL DATA			
Switching capacity max.	10W/VA	Fall Time max.	0.3 ms
Switching current max.	0.7 A	Switching frequency max.	500 Hz
Continuous current max.	1 A	Resonant Frequency type	5000 Hz
Switching voltage max.	24 V AC/DC (Max. 30 V)	Vibration (50-2000 Hz)	20 G
Dielectric strength min.	200 VDC	Shock resistance (1 / 2 sin 11 ms)	50 g
Contact resistance max.	100 mΩ	Operating temperature	-20 to +85 °C
Protection	IP 65	Switch points	4 to 8 bar
Switching time max.	0,5 ms		

5.1.3 Connection of pressure gauge with contacts

Cable features	Materials	Applications
Number: 3 cables Conductor cross section: 0,14 mm ² Cable material: PVC coated Cable length: 1 m Colors - Circuit diagram: see label on the case of the gauge	Case: Stainless Steel Measuring element: copper alloy Motion work: copper alloy Dial: aluminum white Pointer: black plastic Viewing glass: polycarbonate	Pressure monitor inside the vessels. Pressure monitor of the Easydetect tube.

GENERAL FEATURES		
Code	054006	054016
Contact	N.O.	N.C.
Switching mode	Without pressure → contact opened (NO)	Without pressure → contact closed (NC)
Pressure above switch point	Contact close	Contact open
Pressure range	0 – 40 bar	
Set points	5 bar and 17 bar	
Switching tolerance	±4% full scale value	
Accuracy class	2.5	
Nominal size	50 mm	
Ingress protection	IP65 according to EN60529 / IEC 529	
Helium leakage test	leakage rate 10 -5 mbar l/s	

ELECTRICAL DATA			
Switching voltage	4.5 V ... 24 VDC / VAC (±30%)	Compressive strength steady load	3 / 4 x full scale value
Switching current	5... 100 mA	Compressive strength fluctuating load	2 / 3 x full scale value
Contact load	Max 2,4 W	Short-time	full scale value
Operating Medium temperature	+50 °C	Operating ambient temperature	-20 ... +50 °C



Figure 23 - Status of pressure gauge contacts

6 COMMISSIONING

6.1 Pressurising the Easydetect tube



Before being able to open the cylinder valve after system installation, the Easydetect tube must be pressurised.

The Easydetect tube is pressurised at an operational pressure of 18 bar (+/-0.25) at 20 °C, to ensure a faultless system function. Use only pure nitrogen as pressurising gas to guarantee better long-lasting results.

For pressurization use only the AIRfire Easyfill (125307).

Instructions:

Unscrew the pressure gauge or Signal transmitter (depends on system configuration) from the end of line adapter of the Easydetect tube.

Screw firmly the "Filling connector M10 x 1 adapter (tool n° 6 - Section 3.7)

Connect a prepared piece of Easydetect tube between outlet 4 x 6 of the Easyfill and the inlet of the filling connector M10x1.

Open filling connector valve and then gradually open the Easyfill ball valve, wait approximately 15 seconds while the tube is pressurised. The Easyfill valve regulates the outlet pressure to 18 bar.

After these 15 seconds, close Easyfill ball valve and then filling connector valve and disassemble the Easydetect tube and filling connector. Care must be taken with the residual pressure in the tube, may cause back lash, whip effect.

Check the pressure of the Easydetect tube connecting the pressure gauge. Needle should position itself in the green zone. If it hasn't reached, repeat procedure until needle is in correct position.

Finally, re-assemble the signal transmitter / pressure gauge.

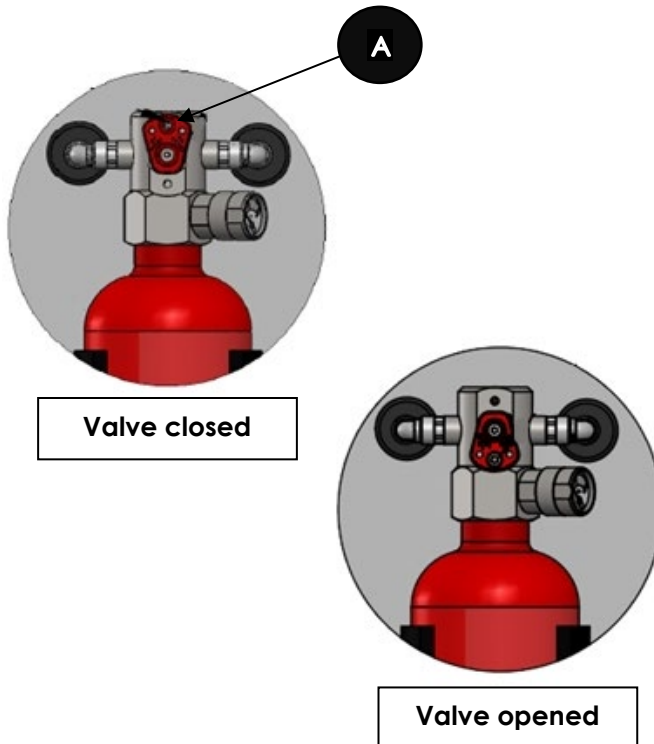

Figure 24 – Pressurising the Easydetect tube

6.2 Opening cylinder valve



The cylinder valve may only be opened when the Easydetect sensor tube has been connected to the valve. Furthermore, the sensor tube must have been pressurized with nitrogen at 18 bar and leak tested (see previous section, 5.1).



Instructions:

Unscrew the safety screw (fig. 20-A) and open the ball valve turning the lever anticlockwise 180°.

Re screw the safety screw, to lock and avoid ball valve manipulation.

Figure 25 - Cylinder ball valve position

6.3 Installation Quick Check

After completion of the installation the following points should be checked again:

- Is the cylinder mounted correctly?
 - In an upright (vertical) position?
 - To a robust firm surface? whether wall or floor.
 - Clamp fastener in its position?
 - Cylinder label visible?

- Has the sensor tube been installed and connected correctly?
 - Is the tube located as close as possible to the fire hazards in the enclosure?
 - Is the tube uncovered and unobstructed?
 - Is the tube free of tight bends, kinks and firmly secured inside the enclosure?
 - Is the operating pressure of the Easydetect tube to 18 bar (green zone of the pressure gauge)?

- Have the electrical components been connected properly?
 - Can the power supply be switched off in an emergency?
 - If not, has it been duly notified?
 - Does the alarm work?
 - Can the forced ventilation be turned off upon system activation?

- Have the labels been fixed to the enclosure stating use of fire suppression system?

- Have any components been damaged during the installation work?

- Has the cylinder valve been opened?

If after an objective inspection no fault or error is visible the system can be approved, and protected enclosure used.

7 OPERATIONS

7.1 Automatic fire detection

ARMANfire is fitted with the Easydetect tube (pneumatic sensor tube) that acts as a fire detector. If there is a fire the tube will react to the increasing heat/ flame impingement and burst. The resulting pressure drop activates the cylinder valve and the extinguishing agent is expelled through the hole produced to the Easydetect tube when burst.

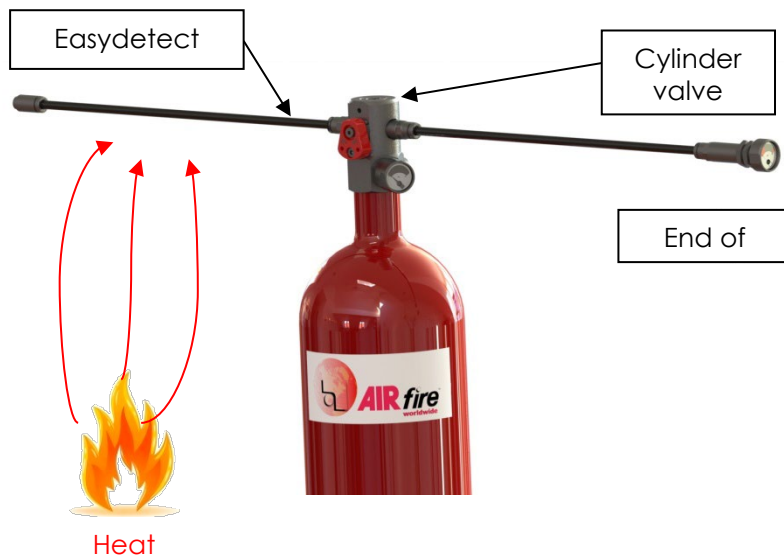

Figure 26 – Heat/ flame detection

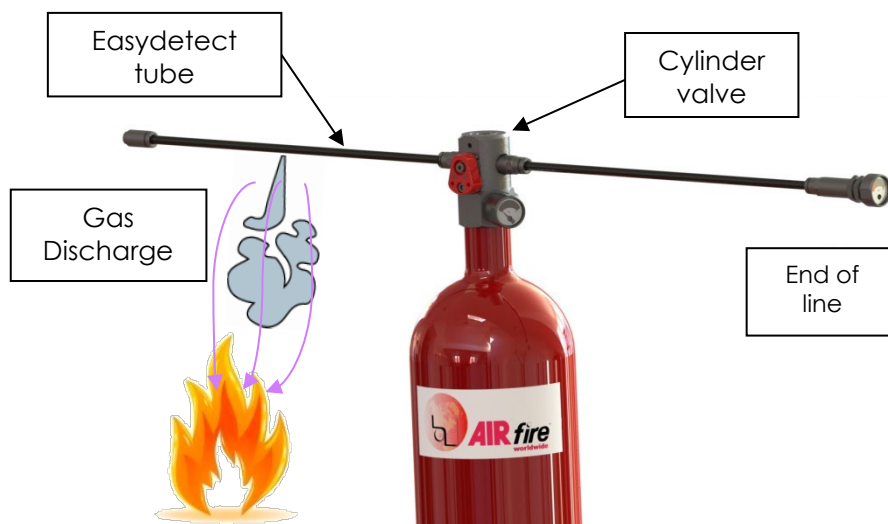

Figure 27 - Agent discharge through burst tube

8 SERVICING/ MAINTENANCE



System maintenance and servicing is extremely important to ensure the functionality of the system on a long-term basis and to reinstate it after a fire has been extinguished.

All work may only be performed by qualified and trained personnel.

8.1 Reinstatement work after system discharge

8.1.1 Replacement of single use components

Some system components are designed for single use only. Any further use of these would alter the functionality. They cannot be reused due to such factors as wear and tear, damage or soiling...

The following components **must** be replaced after system activation:

- Easydetect tube, the piece where the burst hole is located.
- Plastic mounting elements for the Easydetect tube
- All other damaged or unusable components

8.1.2 Replenishing discharged extinguishing agent

For replacing the extinguishing agent contact directly **AIRfire Worldwide (international office)**.

8.2 Servicing after an interval

8.2.1 Service intervals

Service type	Work to be carried out	Interval
Monitoring the functionality	Checking the functionality and damages	min. once a year by specialist personnel (daily by trained staff)
Revision of wear and tear parts	Check discharge line, Easydetect tube line and its components to find wear and tear parts	min. every 2 years
Replace the agent	Replacement of extinguishing agent and test the vessel with the Hydrostatic pressure test	10 years

8.2.2 Maintenance schedule

System age	Monitoring the functionality	Revision of wear and tear parts	Replace the agent
1 year	X		
2 years	X	X	
3 years	X		
4 years	X	X	
5 years	X		
6 years	X	X	
7 years	X		
8 years	X	X	
9 years	X		
10 years	X	X	X



Defective components must be replaced immediately

8.2.3 Yearly check – System functionality check

To ensure the long-term functionality of the system the operational state of the extinguishing system must be inspected once a year by service personnel qualified by AIRfire.

First, the pressure gas volume must be checked, and if necessary be replenished with nitrogen to 18 bar (+/-0.25).

Replenishing the pressure gas of the cylinders:

- The ball valve on the cylinder valve(s) must remain open.
- Filling is done via the sensor tube because the system would be activated if it is replenished via the cylinder valve.



Use only the Easyfill (125307) or a similar device with a filling pressure of 18 bar (nitrogen). In addition, components such as the sensor tube and mounting elements must be checked for wear and tear, aging and other damages, and if necessary be replaced.

For restarting procedure the system, proceed as described in the "Installation" chapter.

8.2.4 Biannual check – Checking operational state of components

The operational system pressure and the pressure gas volume can be checked by the pressure gauge. Operational pressure: 18 bar (+/-0.25).

Depending on the system design there are standard pressure gauges available for system pressure monitoring. These are located at the end-of-line adapter (125204) and on the cylinder valve (if no contact gauge is installed). The pressure should be checked with precise pressure gauge with switch contacts.

The tube shall be fitted properly in the risk zone and not covered up, as described in section 4.3 (Installation of the Easydetect tube).

The mounting and fastening elements for the Easydetect tube and pressure vessels may not be damaged or bent. There must be no slack, all elements must be securely mounted and fixed.

8.2.5 10year check – General maintenance

During the general maintenance and in addition to the normal servicing work the extinguishing agent is replaced, including the dip tube. The entire depressurized system is to be checked for damage and wear and tear; affected components must be replaced.

The new installation of the components are described in Chapter 4, Installation.

8.3 Service and maintenance records

Reports on any problems or issues encountered shall be kept, with the following details:

- False alarms
- Assembly, installation problems
- Maintenance, service problems
- Insufficient product training
- Customer complaints
- Criticism, improvement suggestions



These reports shall be maintained by the installation company for site auditing purposes and copies sent to AIRfire for LPCB audit.

For a new installation and any maintenance and service work, records must be kept, completing the table found in Annex 4.

9 APPROVAL AND MARKING OF SYSTEM

Correctly installed fire extinguishing systems for electrical enclosures complying with the specifications in this document may be marked by the authorised installer with the mark as below:



Standard	LPS1666
Issue	1.0
Cert. No.	1408c

And with the additional optional notice "Direct low pressure (DLP) system approved as per

Figure 28 - LPCB certification mark

LPS1666, Issue 1.0".

The suitability, reliability and functionality of the direct low-pressure application fixed fire suppression system ARMANfire was tested and approved by the Loss Prevention Certification Board (LPCB) of BRE Global Ltd. according to LPS1666. A copy of the certificate is available from the system manufacturer AIRfire on request.

A condition for the use of the marking is the listing as an approved manufacturer in the LPCB Redbook of BRE Global Ltd. (<http://www.redbooklive.com>) and the authorization of AIRfire. For further information and requirements for the use of the "LPCB Certification Mark" refer to the standards authority documentation in PN103 – Rules and Guidance for use of the LPCB Certification Marks.



Only system designed, planned, installed, serviced and maintained by an authorised installer may be marked accordingly. All other systems are not covered by this system certification. The above mark is only legally valid in conjunction with the respective certificates.

A visible marking of the system regarding hazards and operations is to be mounted on the pressure vessels. Marking is to be according to the requirements specified on the following page.

10 PRODUCT LIABILITY

The General Terms and Conditions of AIRfire are available on our website at www.airfire.eu. On request, we will be pleased to mail them to you.

Contact details:

AIRfire Worldwide S.L.
 C/ Mata 21, local
 08004 Barcelona - Spain
 Tel: (+34) 933 24 90 94



As per standard LPS 1666 it is mandatory the fixing of the supplied labels with the system to indicate that the protected electrical enclosure must not be operated in case that the extinguishing system is out of commission.

See Annex 5.

ARMANfire®

FK-5-1-12



LPS 1666: Issue 1.0
Cert/LPCB ref. 1408c

ARFFK501TB

ARFFK502TB

ARFFK503TB

ARFFK504TB

ARFFK506TB

NOTE: System can protect a maximum volume of 2 m³.

FILLED WITH FK-5-1-12
CARICA DI FK-5-1-12
CHARGÉ AVEC FK-5-1-12

1 kg

2 kg

3 kg

PRESSURIZED AT
PRESSURIZZATO A
PRESSURISÉE À

18

BAR (T = 20 °C)

CYLINDER nr. CILINDRO n° BOUTEILLE n°	
TOTAL WEIGHT (kg) PESO TOTALE (kg) POIDS TOTAL (kg)	
FILLING DATE DATA DI RIEMPIMENTO DATE DE REEMPLISSAGE	

STORAGE TEMPERATURE: -20 °C to + 60 °C
TEMPERATURA DI STOCCAGGIO: -20 °C a + 60 °C
TEMPERATURE DE STOCKAGE: -20 °C à + 60 °C

Date of installation:
Data di installazione:
Date d'installation:

Date of next service:
Data della prossima revisione:
Date du prochain service:

Authorised Installer:
Installatore Autorizzato:
Installateur Autorisé:

WARNING: Authorised Installer or AIR fire must be contacted before altering or modifying the installation.

AIRfire®

SEDE - HEADQUARTERS:
Via Tenuta della Mistica, 33/37 - 00155 ROMA
Tel +39 06227341 - Fax +39 062288044
info@airfire.it - www.airfire.it

FILIALE INTERNAZIONALE - INTERNATIONAL DIVISION:
BARCELONA - info@airfire.eu - www.airfire.eu

Label code: 141021

Figure 29 – Chemical agents cylinder labels

11 ANNEX 1 – SYSTEM LAYOUT

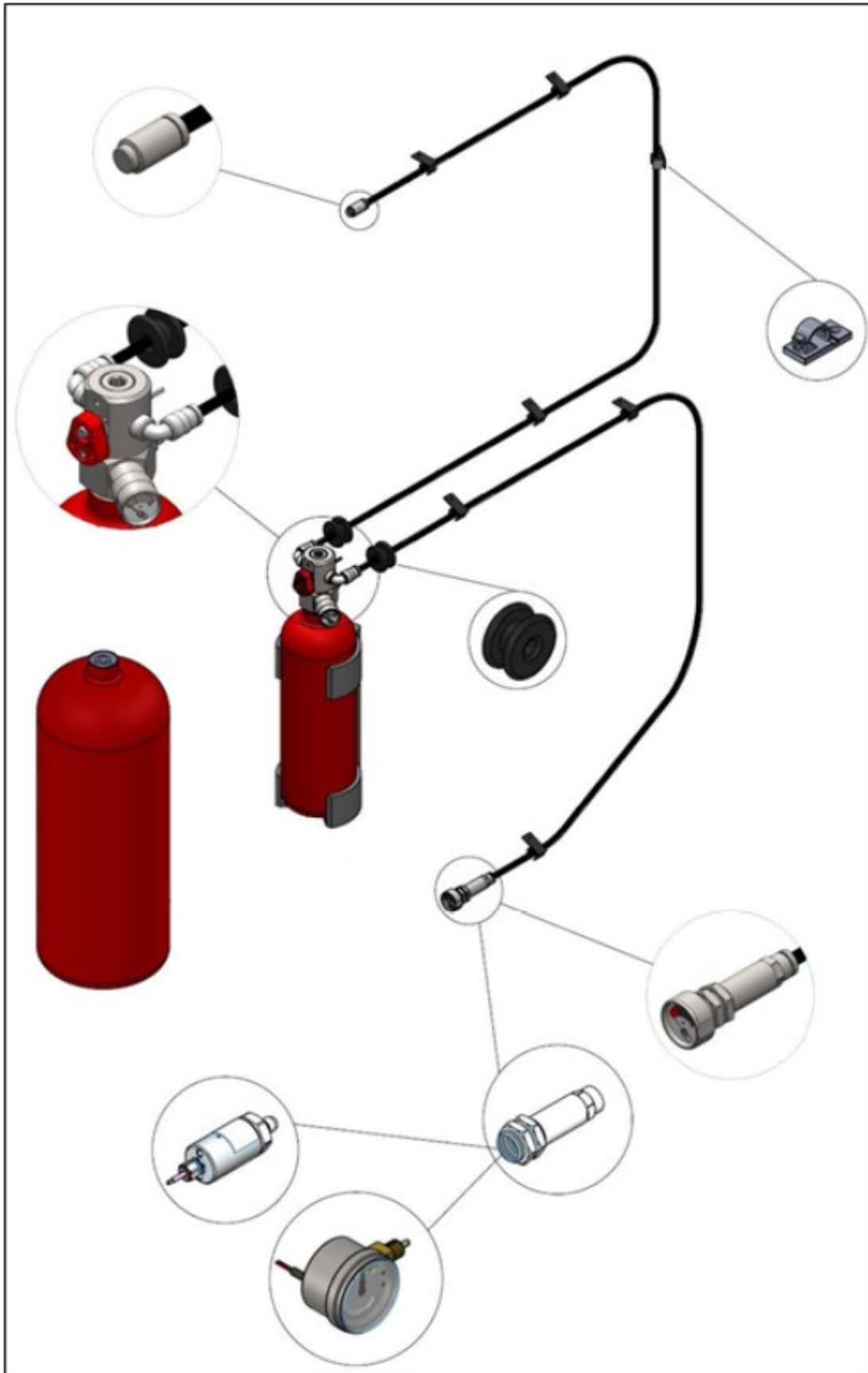

12 ANNEX 2 – FK-5-1-12 FEATURES

SECTION 1: IDENTIFICATION OF THE SUBSTANCE/MIXTURE / UNDERTAKING

Product identifier

Product name: **FK-5-1-12**

IUPAC Nomenclature: 1,1,1,2,2,4,5,5,5-Nonafluoro-4-(Trifluoromethyl)-3-pentanone

Relevant identified uses of the substance or mixture and uses advised against

Relevant identified uses: Extinguishant

SECTION 2: HAZARDS IDENTIFICATION

OSHA/HCS status:

This material is not classified as hazardous according to the OSHA Hazard Communication Standard (29 CFR 1910.1200)

Classification of the substance or mixture:

Not classified

GHS label elements:

Not applicable

Hazard pictograms:

Not applicable

Signal word:

Warning

Hazard statements:

H317: May cause an allergic skin reaction.

H319: Causes serious eye irritation Precautionary statements

Precautionary statements:

P233: Keep container tightly closed in a cool/well-ventilated place

P260: Do not breathe dust/fumes/gas/vapours/spray

P273: Avoid release to the environment

P280: Wear protective gloves/protective clothing/eye protection/face protection

P305+351+338 IF IN EYES: Rinse cautiously with water for several minutes.

Remove contact lenses if present and easy to do - continue rinsing.

Other Hazard:

May decompose on contact with flames or extremely hot metal surfaces to produce toxic and corrosive products.

In high concentrations, vapors may reduce oxygen available for breathing. Liquid contact with eyes or skin may cause mild irritation.

SECTION 3: COMPOSITION/INFORMATION ON INGREDIENTS

Ingredient name: 1,1,1,2,2,4,5,5,5-Nonafluoro-4-(trifluoromethyl)-3-pentanone

CAS No.: 756-13-8

%(weight): ≥99.60

SECTION 4: FIRST AID MEASURES

Description of first aid measures

Inhalation Remove to fresh air Oxygen or artificial respiration if needed If unconscious, place in recovery position and get medical attention immediately

Skin contact Flush exposed skin with lukewarm water (not hot), or use other means to warm skin slowly Remove contaminated clothing and shoes Get medical attention if frostbitten by liquid or if irritation persists

Eyes contact Immediately flush with large amounts of water for at least 15 minutes Get medical attention if irritation occurs

Ingestion DO NOT induce vomiting unless instructed to do so by a physician. Get medical attention immediately if symptoms develop.

Note to physician Immediate medical attention is not required When symptoms persist or in all cases of doubt seek medical advice

SECTION 5: FIREFIGHTING MEASURES

5.1. Suitable extinguishing media

Product is a fire-extinguishing agent. Material will not burn. Use a fire fighting agent suitable for the surrounding fire.

5.2. Special hazards arising from the substance or mixture

Exposure to extreme heat can give rise to thermal decomposition.

Hazardous Decomposition or By-Products

Substance:	Condition:
Carbon monoxide	During Combustion
Carbon dioxide	During Combustion
Toxic Vapor/Gas	During Combustion

5.3. Special protective actions for fire-fighters

When fire fighting conditions are severe and total thermal decomposition of the product is possible, wear full protective clothing, including helmet, self-contained, positive pressure or pressure demand breathing apparatus, bunker coat and pants, bands around arms, waist and legs, face mask, and protective covering for exposed areas of the head.

SECTION 6: ACCIDENTAL RELEASE MEASURES

6.1. Personal precautions, protective equipment and emergency procedures

Evacuate area. Ventilate the area with fresh air. For large spill, or spills in confined spaces, provide mechanical ventilation

to disperse or exhaust vapours, in accordance with good industrial hygiene practice. Refer to other sections of this SDS for information regarding physical and health hazards, respiratory protection, ventilation, and personal protective equipment.

6.2. Environmental precautions

Avoid release to the environment. For larger spills, cover drains and build dikes to prevent entry into sewer systems or bodies of water.

6.3. Methods and material for containment and cleaning up

Contain spill. Working from around the edges of the spill inward, cover with bentonite, vermiculite, or commercially available inorganic absorbent material. Mix in sufficient absorbent until it appears dry. Remember, adding an absorbent material does not remove a physical, health, or environmental hazard. Collect as much of the spilled material as possible. Place in a closed container approved for transportation by appropriate authorities. Seal the container. Dispose of collected material as soon as possible.

SECTION 7: HANDLING AND STORAGE

7.1. Precautions for safe handling

Contents may be under pressure, open carefully. Do not breathe thermal decomposition products. For industrial or professional use only. Do not use in a confined area with minimal air exchange. Do not eat, drink or smoke when using this product. Wash thoroughly after handling. Avoid release to the environment.

7.2. Conditions for safe storage including any incompatibilities

Protect from sunlight. Store in a well-ventilated place. Store at temperatures not exceeding 38C/100F Store away from strong bases. Store away from other materials. Store away from amines.

SECTION 8: EXPOSURE CONTROLS/PERSONAL PROTECTION

8.1. Control parameters

Occupational exposure limits

If a component is disclosed in section 3 but does not appear in the table below, an occupational exposure limit is not available for the component.

Ingredient C.A.S. No. Agency Limit type Additional Comments

1,1,1,2,2,4,5,5,5-Nonafluoro-4-(trifluoromethyl)-3-pentanone
756-13-8 Manufacturer determined

TWA:150 ppm(1940 mg/m³)

ACGIH : American Conference of Governmental Industrial Hygienists

AIHA : American Industrial Hygiene Association

CMRG : Chemical Manufacturer's Recommended Guidelines

OSHA : United States Department of Labor - Occupational Safety and Health Administration

TWA: Time-Weighted-Average

STEL: Short Term Exposure Limit

CELL: Ceiling

8.2. Exposure controls

8.2.1. Engineering controls

Provide appropriate local exhaust when product is heated. For those situations where the material might be exposed to extreme overheating due to misuse or equipment failure, use with appropriate local exhaust ventilation sufficient to maintain levels of thermal decomposition products below their exposure guidelines. Use general dilution ventilation and/or local exhaust ventilation to control airborne exposures to below relevant Exposure Limits and/or control dust/fume/gas/mist/vapours/spray. If ventilation is not adequate, use respiratory protection equipment.

8.2.2. Personal protective equipment (PPE)

Eye/face protection

Eye protection not required.

Skin/hand protection

No protective gloves required.

Respiratory protection

Use a positive pressure supplied-air respirator if there is a potential for over exposure from an uncontrolled release, exposure levels are not known, or under any other circumstances where air-purifying respirators may not provide adequate protection.

If thermal degradation products are expected, use a full facepiece supplied-air respirator.

SECTION 9: PHYSICAL AND CHEMICAL PROPERTIES

9.1. Information on basic physical and chemical properties

General Physical Form: Liquid

Specific Physical Form: Liquid

Odour, Colour, Grade: Clear colourless liquid with low odour

Odour threshold *No Data Available*

pH *Not Applicable*

Melting point -108 °C

Boiling Point 49 °C [@ 760 mmHg]

Flash Point No flash point

Evaporation rate > 1 [Ref Std: BUOAC=1]

Flammability (solid, gas) Not Applicable

Flammable Limits (LEL) None detected

Flammable Limits (UEL) None detected

Vapor Pressure 40.4 kPa [@ 25 °C]

Vapor Density 11.6 [Ref Std: AIR=1]

Specific Gravity 1.6 [@ 68 °F] [Ref Std: WATER=1]

Solubility in Water Nil

Solubility- non-water *No Data Available*

Partition coefficient: n-octanol/ water *No Data Available*

Autoignition temperature *Not Applicable*

Decomposition temperature *No Data Available*

Viscosity 0.6 centipoise [@ 25 °C]

Molecular weight *No Data Available*

Volatile Organic Compounds 1600 g/l [Test Method: calculated SCAQMD rule 443.1]

Percent volatile 100 %

VOC Less H2O & Exempt Solvents 1600 g/l [Test Method: calculated SCAQMD rule 443.1]

SECTION 10: STABILITY AND REACTIVITY

10.1. Reactivity

This material may be reactive with certain agents under certain conditions - see the remaining headings in this section.

10.2. Chemical stability

Stable.

10.3. Possibility of hazardous reactions

Hazardous polymerization will not occur.

10.4. Conditions to avoid

Light

10.5. Incompatible materials

Strong bases

Amines

Alcohols

10.6. Hazardous decomposition products

Substance Condition

Hydrogen Fluoride At Elevated Temperatures - extreme conditions of heat

Refer to section 5.2 for hazardous decomposition products during combustion.

If the product is exposed to extreme condition of heat from misuse or equipment failure, toxic decomposition products that include hydrogen fluoride and perfluoroisobutylene can occur. Extreme heat arising from situations such as misuse or equipment failure can generate hydrogen fluoride as a decomposition product.

SECTION 11: TOXICOLOGICAL INFORMATIONS

11.1. Information on Toxicological effects

Signs and Symptoms of Exposure

Based on test data and/or information on the components, this material may produce the following health effects:

Inhalation:

No known health effects.

Skin Contact:

Contact with the skin during product use is not expected to result in significant irritation.

Eye Contact:

Contact with the eyes during product use is not expected to result in significant irritation.

Ingestion:

May be harmful if swallowed.

SECTION 12: ECOLOGICAL INFORMATION

Ecotoxicological information

Test Organism Test Type Result

Green algae, Selenastrum capricornutum 72 hours Effect Concentration 50% 7.7 mg/l

Zebra Fish, Brachydanio rerio 96 hours Lethal Concentration 50% >1200 mg/l

Water flea, Daphnia magna 48 hours Effect Concentration 50% >1200 mg/l

Green algae, Selenastrum capricornutum 72 hours No obs Effect Conc 1.2 mg/l

Please contact the address or phone number listed on the first page of the SDS for additional ecotoxicological information on this material and/or its components.

Chemical fate information

Please contact the address or phone number listed on the first page of the SDS for additional chemical fate information on this material and/or its components.

SECTION 13: DISPOSAL CONSIDERATIONS

13.1. Disposal methods

Dispose of contents/ container in accordance with the local/regional/national/international regulations.

Dispose of waste product in a permitted industrial waste facility. As a disposal alternative, incinerate in a permitted waste incineration facility. Proper destruction may require the use of additional fuel during incineration processes. Combustion products will include HF. Facility must be capable of handling halogenated materials.

Empty drums/barrels/containers used for transporting and handling hazardous chemicals (chemical substances/mixtures/preparations classified as Hazardous as per applicable regulations) shall be considered, stored, treated &

disposed of as hazardous wastes unless otherwise defined by applicable waste regulations. Consult with the respective regulating authorities to determine the available treatment and disposal facilities.

EPA Hazardous Waste Number (RCRA): Not regulated

SECTION 14: TRANSPORT INFORMATION

UN, IMDG, IATA No.	UN 3296
UN, IMDG, IATA proper shipping name	Heptafluoropropane (Refrigerant Gas, R 227)
Transport hazard class	2
Packing instructions	P200
Environmental hazards classified as a Marine Pollutant	Not
Special precautions for user	Kemler
Number: 20 (Asphyxiant Gas)	
EMS number: F-C, S-V	

13 ANNEX 3 – TRAINING PROGRAMME

As per LPS1666: Issue 1.0, the design, installation and maintenance of approved systems must be carried out by trained installers authorised and monitored by the listed manufacturer, AIRfire.

The following programme shall be followed to obtain the certificate to become Authorised Installer for ARMANfire systems.



Figure 30 - Training certificate

Training Course, based on the Manuals provided with the systems, divided into 2 sessions:

Design and Calculations Training, how to interpret and understand typical applications, evaluate special configurations and calculate the necessary system.

Installation and Maintenance Training, theoretical-practical training covering the different steps to install, commission and maintain the systems.

A test is carried out at the end of the course so to confirm all concepts are understood and validate Installers training, along with the delivery of a numbered certificate.

Record of test papers and copies of certificates are maintained by AIRfire for auditing purposes carried out by LPCB.

Refresher Course shall be carried out to maintain certification at least every 5 years. In case the system has undergone substantial updates before this time, Authorised Installers will be notified and provided with necessary training.

14 ANNEX 4 – SERVICE AND MAINTENANCE CHECK LIST

This table shall be filled out and sent to AIRfire for its records of the system supplied

General features			
Installation location		Installation company	
Installation date		Name of installation engineer	
Chemical agent type			
System variant			

First start-up			
Operation pressure [bar]		Actuation monitoring available?	<input type="checkbox"/>
Leakage test OK?	<input type="checkbox"/>	Alarm (optical/acoustic) available?	<input type="checkbox"/>
Extinguishing agent amount [Kg]		Leakage monitoring available?	<input type="checkbox"/>
Sensor tube routing OK?	<input type="checkbox"/>	Vessel in upright position?	<input type="checkbox"/>
Valves opened?	<input type="checkbox"/>	All components undamaged?	<input type="checkbox"/>
All handbook points covered?	<input type="checkbox"/>		
Other features			

Service and maintenance			
Date of maintenance		Name of the installer	
Reason for system activation			
Replaced components			
Reused components			
Other features			
Operation pressure [bar]		Is the valve opened?	<input type="checkbox"/>

Scheduled servicing after interval			
Date of maintenance		Name of the installer	
Reason for maintenance	Monitoring the functionality (annual) <input type="checkbox"/>	Revision of wear and tear parts (every 2 years) <input type="checkbox"/>	Replace the agent (every 10 years) <input type="checkbox"/>
Replaced components			
Servicing and maintenance work carried out according to chapters 7?			
Other features			
Operation pressure [bar]		Are the valves opened?	<input type="checkbox"/>

15 ANNEX 5 – Caution label for protected enclosure

Compulsory to be installed on all enclosures protected by an ARMANfire system.



Label code: 141016

Figure 31 - Caution label

16 List of figures

Figure 1 - Ball valve position	8
Figure 2 - Cylinder layout	11
Figure 3 - Compensation volume	12
Figure 4 - Cylinder valve	12
Figure 5 - Easydetect sensor tube	13
Figure 6 - Easydetect tube fittings	14
Figure 7 - ARMANfire bracket	14
Figure 8 – Signal transmitter	15
Figure 9 - Pressure gauge with contact	15
Figure 10 - Starterkit	16
Figure 11 - Mounting position	17
Figure 12 - Cylinder in bracket	18
Figure 13 - Cylinder in bracket	18
Figure 14 – Cylinder floor bracket	19
Figure 15 - Easydetect tube	20
Figure 16 - Easydetect tube routing example	21
Figure 17 - Grommet positioning	22
Figure 18 – Deburring tool 1	22
Figure 19 – Deburring tool 2	23
Figure 20 – Deburring tool 3	23
Figure 21 - System monitoring scheme	24
Figure 22 – Status of pressure switch without pressure	25
Figure 23 - Status of pressure gauge contacts	26
Figure 24 – Pressurising the Easydetect tube	27
Figure 25 - Cylinder ball valve position	28
Figure 26 – Heat/ flame detection	30
Figure 27 - Agent discharge through burst tube	30
Figure 28 - LPCB certification mark	34
Figure 29 – Chemical agents cylinder labels	35
Figure 30 - Training certificate	42
Figure 31 - Caution label	44