



5150-W

On-the-glass piezo sensor with wire leads

The Sentrol 5150 series glass break detector has been designed using the latest electronic techniques. This enables the detector to contain all the necessary circuitry for excellent detection whilst filtering out and rejecting all unwanted signals that would normally result in a nuisance alarm(s), e.g. ultra-sound, radio frequency interference, etc. The 5150 series will provide a 3 m radius of protection. Suitable for use on standard window glass, plate, wired, tempered and laminated glass.

Due to the design of the product, the detector may be fitted as close as 2.5 cm from the window frame and still provide a full 3 m radius. The 5150 series detectors are passive sensors; therefore any number of detectors may be installed on the same windowpane without the risk of interaction.

The detectors use a fail-safe, normally closed, open to alarm relay contact enabling compatibility with any standard burglar alarm control equipment.

The output from the relay contact should be connected via the alarm 24-hour tamper loop in order to provide early signaling at the control whether the alarm is switched on or off. The opening of the normally closed relay contact signals the alarm.

Easily installs with pre-cut specially formulated 3M adhesive tape.



Standard Features

- 3 m radius of coverage measured from the sensor
- Protects all glass types up to a standard thickness of 6.4 mm including plate, wired, tempered and laminated glass
- Ideal for 24-hours loop protection
- Two wire sensor, drawing no power from the loop
- Compatible with most wireless transmitters

5150-W

On-the-glass piezo sensor with wire leads

Specifications

Operating voltage	N/A
Current draw	N/A
Relay output	NC, open 1-10 sec on alarm
Range	3 m radius
Glass types	Plate, wired, tempered, laminated
Dimensions (L x W x H)	32 x 32 x 12 mm
Tamper switch	No
Color	White
Connections	3 m jacketed wire leads

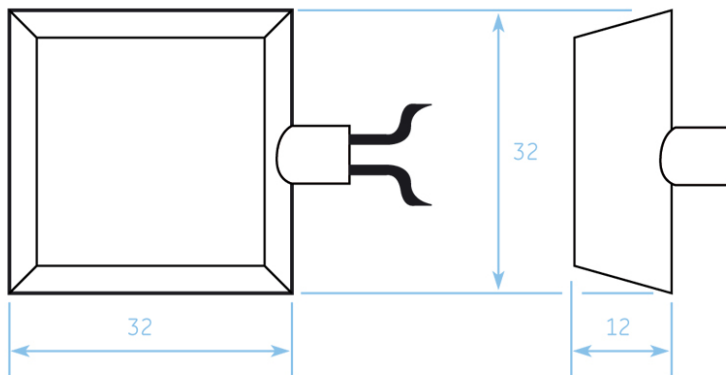

Ordering Information

Part No.	Description
5150-W	On-the-glass piezo sensor with 30 cm wire leads, covering up to 3 m of glass.



www.gesecurity.net